

Strategic Infrastructural Development

Application to An Bord Pleanála
[Reg. No. PL. 61. PA0033]

Oral Hearing
Galway Harbour Extension

Engineering Brief of Evidence – Part 1

Presented by:-

Eamonn Waldron
TOBIN Consulting Engineers

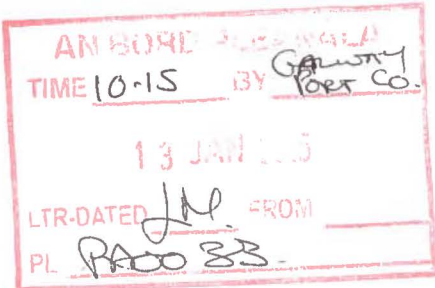

January 2015



1 INTRODUCTION

1.1 EXPERIENCE

Slide 1 – Cover Photo [Realsim image of Overall Development]

My name is Eamonn Waldron.

I am a Chartered Engineer with over 40 years experience in the planning, design, impact assessment, construction and supervision of major civil engineering projects throughout Ireland.

Relevant Schemes I have managed include:-

- River Fane Water Supply Scheme in Co. Louth.
- Lough Mask Regional Water Supply Scheme in Co. Mayo.
- Waste Water Treatment Plant to cater for the combined towns of Leixlip, Maynooth and Kilcock.
- Planning, licensing and construction of major engineered landfill sites at Kilconnell (Galway) and Bottle Hill (Cork).

I am a Director of TOBIN Consulting Engineers and currently, Chairman, and have acted in the role of Project Director for the Galway Harbour Extension project since 2011.

I will be presenting part of the engineering evidence for the proposed extension to Galway Harbour.

At the outset I will explain the Background to the Project, describing the existing situation, constraints and the need for the project. I will describe the facilities to be provided, the construction methods envisaged and the phasing proposed will also be described.

As regards reference levels all terrestrial or ground levels are to metres Ordnance Datum Malin Head [m O.D.]. Marine levels are to metres Chart Datum [m C.D.].

Zero metres Chart Datum is akin to Lowest Astronomical Tide [LAT] and is equal to -2.9 m O.D. [Malin].

1.2 BACKGROUND

Slide 2 – Drg / 2116 [Existing Docks & GHEP]

Galway Harbour Company has for some years, been developing proposals for a Harbour Extension at Galway to address severe constraints to their operations within the existing harbour resulting from:-

- having a severely restricted access,
- being a tidal and gated harbour,
- with an entrance channel that is too shallow,
- with a port draught and dimensions that are too limited,

- having an inadequate quay length and a limited berthage,
- and with an uneconomic vessel size capacity.

The proposed Galway Harbour Extension [GHE] development will address all of the above constraints and provide improved infrastructure to consolidate existing business, develop new business and services, provide for the international cruise liner business, accommodate marine leisure and amenity and tourism, upgrade fishing facilities and facilitate the economic growth of the region. The development will include the relocation of the majority of the existing Harbour related activities, including oil and bitumen discharges and other businesses to new Quays, Jetties and Yards to be located at the Galway Harbour Extension.

Slide 3 – Drg. / 2117 [Site Layout Map]

The proposed extension will be developed on reclaimed lands to the South of the existing Galway Harbour Enterprise Park. The area within which the development is proposed, while adjacent to the Galway Harbour Enterprise Park is in an area designated candidate Special Area of Conservation [cSAC], Special Protection Area [SPA] [both of which are Natura 2000 sites] and in a proposed National Heritage Area [pNHA].

Over the period 2007-2013, Galway Harbour Company has been in consultation with An Bord Pleanála under Section 37B of the Planning and Development Act, 2000, as amended, on the proposals for the Galway Harbour Extension. An Bord Pleanála decided in October 2013 that the proposed development would be strategic infrastructure within the definition of Section 37A of the Planning and Development Act, 2000, as amended, and that any application for permission for the proposed development must be made directly to An Bord Pleanála under Section 37E of the Act.

2 GALWAY HARBOUR COMPANY

Slide 4 – 1820 Map of Galway [Fig. 1.3.1, EIS Vol 2B – part 1]

2.1 BRIEF HISTORY

The original medieval Port of Galway was located in the River Corrib, adjacent to the present day Spanish Arch [No. 1 on slide 4].

Also to be seen on this slide are [2] the Claddagh Quays, [3] the existing Mud dock and [4] a natural lagoon to the east.

Under the Harbours Act of 1835 a new commercial harbour, largely to the current configuration, was developed in this natural lagoon. That layout would at that time be capable of serving 2,000 Tonne vessels.

Also to be seen in that slide are Lough Athalia and Rinmore Point.

Slide 5 – 1945 Map [Fig. 1.3.2, EIS Vol 2B – Part 1]

A 1945 Ordnance Survey map, showing that commercial dock [1], also shows the rail bridge over Lough Atalia [2] and the rail link into the area of the commercial dock. Also to be seen on that map are Nimmo's Pier to the south and the Port Sanitary Intercepting Hospital at Rinmore Point [3].

Further development works in 1964 involved the deepening of the inner docks area, the provision of additional quay walls and the re-positioning of the dock gates, all to the configuration that exists up to the present time for the inner docks area. That brought the vessel handling capacity to 5,000 Tonne.

Slide 6 – 2011 Aerial Map [Fig. 1.3.3, EIS Vol 2B, Part 1]

In 1995 planning permission was granted to the Galway Harbour Company to develop the Galway Harbour Enterprise Park on the lands on which the Port Sanitary Intercepting Hospital referred to earlier was located. This Enterprise Park is the location for the existing oil and bitumen storage facilities and many other harbour related businesses.

2.2 PORT CONSTRAINTS

Existing operations at the Galway Harbour are constrained in a number of ways.

1. The approach channel to the inner gated harbour [visible as a darker shaded strip on Slide No. 6] has a depth only to -3.4m Chart Datum [CD]. Mean High Water Neaps [NHWN] is 3.9m limiting draught to 7.3m. This channel requires maintenance dredging approximately every 10 years.
2. Navigation into the port via the channel which crosses the outflow from the River Corrib is a complicated manoeuvre when the river is in spate.
3. Vessels accessing the harbour are limited by their draught and sometimes have to be “short-loaded” in order to have sufficient bottom clearance to navigate the channel and the cill of the gate. This is an inherently uneconomic practice.

Slide 7 – Existing Docks [same as Slide 2 – Drg. / 2116]

4. The inner harbour area is controlled by dock gates which can be opened for only two hours before high tide twice daily and are then closed at high tide to retain the required ship water depths. There is therefore only a four hour window in every 24 hour period when vessels can enter or leave the docks. This severely limits the potential of the harbour.
5. In addition to the above, the existing dock gates with an opening width of only 19.81m [65 feet] and a cill level of -3.4m C.D. are a further constraint on the size of vessels that can be accommodated within the inner harbour.

Slide 8 – Jumbo Spirit [Fig. 1.4.1, EIS Vol. 2B, Part 1]

The slide displayed shows the Jumbo Spirit edging its way into the inner docks with a cargo of specialist equipment for a new power plant project in East Galway. The ship had less than 0.3m to spare in the 19.8m ope.

6. Immediately inside the dock gates the Dun Aengus Dock [north and south quays] of total length 325m are dredged to the -3.4m CD. The inner Folan Quay, Quirke Quay, Mulvoy Quay and Breathnach Quay of total length of 547m are dredged to a level some 0.65m higher i.e. to -2.75m, while the South East Extension of total length of 128m and, where the current marina is located, is at the much shallower depth of -0.8m CD.

While this gives a total quay wall length of approximately 1,000m, there is only about 500m useable length of quay wall.

The North and South Dun Aengus Quays, on either side of the deeper section of -3.4m C.D. account for only 32.5% of the total length of quay wall.

Slide 9 - (Drg. 2116 – Existing Docks)

7. Within the existing docks manoeuvring of ships for docking is a very complicated and tricky operation due to the lack of space for a proper turning circle.
8. In addition to the above, as the import of Petroleum Products is a significant trade through the Port and as these are potentially dangerous substances they must comply with the relevant directives and regulations.

The EC COMAH Directive otherwise known as the Seveso II Directive which was implemented in Ireland as SI No. 74 of 2006 governs the handling and storage of these products.

Storage of the products are required to have significant separation distances from some types of land use to ensure safety in the event of a rare but possible major incident. The separation distances required can impose restrictions on the location of such storage and on other developments in their vicinity.

9. Lough Atalia Road is an important artery linking the East and West of Galway City, along Mulvoy Quay and crossing the River Corrib at Wolfe Tone Bridge. This traffic artery is a serious restriction on the ability to operate or expand Port facilities and business at the existing Inner Harbour.
10. Available quay wall lengths and adjacent back up space are severely restricted and cannot be improved to any significant degree due to the immediate proximity of existing heavily trafficked roads and of commercial / residential development.

All of these constraints are limiting the size of vessels that can be accommodated to circa. 5,000Tonnes for liquid, 3,000 Tonnes for dry bulk, which is becoming increasingly uneconomic for customers of Galway Harbour as only 4% of National tonnage is now carried in these smaller vessel types. This view is clearly expressed in many of the submissions made in support of the project. The capacity to cater for 20,000 Tonne liquid, 10,000 – 12,000 Tonne dry bulk is considered to be essential to allow Galway to function as a Regional Port to serve it's hinterland which has 12% of the National population.

If Galway Port declines much of it's hinterland will then be an area of the Country which will be most remote from an effective functioning Regional Port.

In summary the current constraints are:-

- approach channel dredged only to -3.4 CD
- channel navigation can be impacted by high Corrib River flows
- channel and cill restriction results in uneconomical short loading "of small vessels"
- dock gates restricted to two by 2 hour long openings per day
- width of dock gates at 19.81m and cill of -3.4 CD limits the draught and beam of vessel that can enter
- different bed levels within the docks limit the useful area for berthing of larger vessels

- petroleum import within a centre City is not SEVESO Directive compatible
- no potential for expansion of quays and back-up areas due to proximity of heavily trafficked city roads and adjacent commercial and residential developments
- very limited quay wall and adjacent back-up area for marshalling and handling of goods
- the harbour is not accessible by cruise liners and the current limited number who do arrive have to arrange disembarking and embarking by tender outside of Mutton Island, which is very much weather dependent.

3 DESCRIPTION OF FACILITIES

3.1 OBJECTIVES

The development objectives, as outlined in greater detail in Sect. 2.2 of the EIS, can be summarised as follows:-

The harbour extension is required to address the objectives outlined below in the context of insufficient channel depth, narrow and shallow harbour access channel, tidal access restrictions, inadequate quay areas and lengths and restricted vessel turning area.

The objectives are:-

- to meet the current needs of accessibility and capacity for the importation of goods and to thereby arrest the long-term decline in the Port's core traffic
- to attract those regional businesses presently excluded by virtue of the deficiencies in harbour infrastructure
- to benefit from the improved infrastructure and bring new businesses and services to the port
- to enable the Galway region enhance its reputation as a major marine tourism and leisure location
- to be a significant regional Irish visitor destination for the international cruise business
- to sustain local and regional employment
- to facilitate the economic growth of the region
- to provide a direct rail link to the port

3.2 SUMMARY OF PROPOSED DEVELOPMENT

The proposed development will include:-

- quay walls, breakwaters and wave walls to create commercial quays and a deep water docking facility, extending southwards into Galway Bay
- dredging to create a new approach channel to the commercial quays and the deep water docking facility berths
- reclamation of approx. 26.93 ha [23.39 ha reclaimed + 3.04 ha breakwaters]from the foreshore and sea bed
- development of the reclaimed lands and redevelopment of part of the adjacent Galway Harbour Enterprise Park lands for Harbour related business and road and rail access

- a marina on the western side
- fishing quays and a slipway for a nautical centre on the eastern side
- a twin track freight rail link from the existing Galway to Dublin rail line to the commercial quays, including embankments, rail over-bridge to the existing service road and noise abatement screening
- the construction of oil and bitumen transfer pipelines to the existing oil and bitumen tank farms on the Galway Harbour Enterprise Park and the provision of fire water storage facilities. These facilities come within the remit of EU Directive (96/82 EC) on the control of Major Accident Hazards, known as the SEVESO II Directive
- harbour related buildings, including 4 storey Port Operations Office; single storey Harbour Management Warehouse; single storey Marina Office; single storey Passenger Terminal; ancillary car parking and site services, including 2 No. ESB sub-stations, demolition of 1 No. ESB sub-station, 2 No. Control Offices; Oil Terminal Water Pumphouse and a helicopter pad for search and rescue purposes
- the construction and improvement of access roads including the horizontal and vertical realignment of the road under Lough Atalia Road Rail Bridge [a protected structure] and realignment and improvements including traffic lights at Dock Road / Bóthar na Long / Galway Harbour Enterprise Park Access Road junction (adjacent to Harbour Hotel)
- the provision of landscaping and amenity areas, including replacement of the previously permitted amenity strip at the southern seaward boundary of the Galway Harbour Enterprise Park to form an amenity link from the marina on the West to the Nautical Centre on the East
- the proposal includes for all associated temporary and permanent site development [including service roads, realignment of roads and underground works], landscape works [including public lighting and services] and activities to facilitate the construction of the development.

3.3 AREAS FOR DEVELOPMENT

Slide 10 – Drg. 2117A

3.3.1 Overall Area

The overall area for development / re-development as shown on Drawing 2139-2117A comprises of three sub-areas.

Area 1 -	Galway Harbour Extension [GHE] Comprising some existing GHEP land, the reclaimed lands and the dredged areas amounting to:-	82.89 ha
Area 2 -	Galway Harbour Enterprise Park [GHEP] for upgrade of roads and services amounting to:-	1.21 ha
Area 3 -	Lough Atalia Road Upgrade access at Harbour Hotel Junction and improvements at Lough Atalia Road Rail Bridge	1.29 ha
Total Area within Development Site Boundary		85.39 ha

3.3.2 Galway Harbour Extension

Area 1 – measuring 82.89 ha, as referenced above, comprises:-

Land to be reclaimed from the sea	23.89 ha
Breakwater and Revetment Areas	3.04 ha
Total Area to be Reclaimed from Sea	26.93 ha
Dredged Area	46.48 ha
Working Area [Dredge / Marine Construction]	5.30 ha
Total Non-Permanent Works in the Sea	51.78 ha
Existing GHEP Lands to be Re-Developed	4.18 ha
Total Area for Development / Re-development Working Areas, excluding Approach Roads	82.89 ha

Slide 11 – Junction at Harbour Hotel

3.4 ACCESS TO PROPOSED DEVELOPMENT

3.4.1 As part of the project it is proposed to redesign the existing Lough Atalia / Dock Road [adjacent to The Harbour Hotel] priority junction as a smart traffic signal controlled junction in accordance with NRA addendum DMRB TD 50. All harbour related traffic will access the site through this junction. Controlled pedestrian crossing facilities are also proposed on all arms of the junction, thereby facilitating safer pedestrian movement through the junction. Cycle facilities are proposed at this junction in the form of advanced and set-back stop lines and, where space permits, approach cycle lanes.

3.4.2 Slide 12 – Lough Atalia Road Rail Bridge

A height restriction is currently in operation at Lough Atalia Bridge, which restricts high sided vehicle movement to the centre of the road, thus restricting 2-way movement at this location. This has the effect of restricting traffic flow during times of moderate two way flow. More importantly it poses a serious collision risk due to the impact / striking of high vehicles with the bridge cast iron arch [a listed structure]. Records maintained by CIE indicate that such collisions have occurred on a number of occasions down through the years. In conjunction with the proposed development, it is proposed to lower the vertical profile of Lough Atalia Road under the bridge to allow a clearance in excess of the minimum 5.03 metres plus sag compensation, in accordance with NRA TD27, thus allowing for 2-way movement of large HGVs. The horizontal and vertical realignment of Lough Atalia Road has been designed in accordance with NRA TD9 and the Design Manual for Urban Roads and Streets. Details of this proposed realignment and associated drainage proposals can be found in Drawing Numbers 2139-2168 – 2139-2171.

3.4.3 It is proposed that both of the above road improvements / upgrades would be carried out as enabling works in Stage I on the overall development and were therefore included in this planning proposal. In the interim a Part 8 Planning Approval has been granted for this element of the development and the work has been sent out to tender by Galway

City Council with a view to early commencement of construction. This is further detailed in the Road, Traffic and Rail Brief.

- 3.4.4 Access to the proposed development will be via the existing GHEP bridge onto the existing GHEP Road. Spur roads leading to the south off GHEP Road will be upgraded and extended into the new development to form two main access routes.

The main access route, Harbour road, will serve the commercial quay and the fishing pier, while the Marina Promenade Road will provide access to the Marina and adjacent harbour, marina and passenger terminal related buildings.

Slide 13 – Port Security – Drg. 2128

Drawing No. 2128 shows the proposals for security of the working quays and berths within the overall development. It also shows the positioning of the security fencing and the locations of the three main access points into the secured area.

Slide 14 – Drg. 2131 – Open space Proposals

The next drawing shows the arrangements for open space which lies outside of the secured area which has provision for linking the marina on the West to the nautical Centre and slipway on the Eastern side, through a landscaped strip running through the development from West to East. In all 5.81 ha of landscaped areas and open spaces will be provided.

3.5 SERVICES

Services to be provided include:-

- Watermains
- Foul Drainage System
- Storm Water Drainage System
- Saltwater Firefighting Main System
- Ducting systems for fuel lines, bitumen line, gas, electricity and general services.

3.5.1 *Watermain*

The existing 300mm diameter watermain along the main road of the GHEP will be extended with appropriately sized branch main on the adjacent roads. The system will include for bulk flow meter, sluice valves and hydrants all designed to the appropriate standards.

3.5.2 *Foul Drainage System*

A foul drainage system to cater for the proposed buildings, the marina discharge sump and commercial shipping discharges will discharge to a new pumping station to be located near the Harbour Store Building. A rising main from the Pumping Station will connect to an existing rising main which in turn will discharge to the existing Galway City Main Drainage System.

3.5.3 *Storm Water Drainage System*

A comprehensive storm water drainage system comprising of four separate networks will be provided to cater for all surface water generated from all hard surfaces within the proposed development, including roadways, footpaths, buildings, yards and quays. The quay area will be bunded and graded to a drainage channel.

Each drainage network includes a hydrocarbon interceptor and tideflex type non-return valve on the four separate outfalls.

3.5.4 *Salt Firefighting Main System*

A salt water pump system and pumped main with appropriate take-off points will be provided along the commercial quays and will connect to the existing rising main system.

3.5.5 *Ducting Systems*

A concrete chamber to carry 4 fuel lines and one bitumen line in separate compartments will be provided in the access road from the unloading arms to the oil and bitumen storage facilities.

Ducting will also be provided for gas, electricity and other general services.

3.6 FACILITIES TO BE PROVIDED

3.6.1 *Commercial Quay*

At the outer end of the GHE, the commercial quay will provide all of the necessary port facilities for the variety of projected commercial traffic. This zone is divided into three categories, namely the outermost 260metre quay facing North East, to handle oil and bitumen discharges, the adjacent 400metre berth facing South East to provide for the various commercial cargoes, cruise liners and passenger ferries, and the nearby 170metre pier to cater for smaller cargo and larger fishing vessels on the South Westerly Quay, with the smaller inshore fishing vessels being catered for on the North Easterly side of that pier. The proposed dedicated rail connection and port spine access road will provide easy access to this zone.

3.6.2 *Oil / Bitumen Unloading Facilities*

Petroleum is currently discharged from ships docked within the inner Harbour at either Folan Quay or Dun Aengus Quay North through 250mm diameter hoses. These existing discharges are very close to the city centre, its hotels, bars, restaurants, shopping areas and residential properties.

The existing Cold Chon bitumen discharge facility is also located within the existing Inner Harbour.

The proposed development will provide new discharge arrangements at the southern side of the Commercial quays. New marine loading arms and bunded areas with oil interceptors are proposed for this section of quay dedicated to the oil and bitumen unloading and loading facilities.

Oil / bitumen pipelines will run from the jetty underground in a special two compartment concrete chamber or duct to the Topaz and Cold Chon storage facilities.

3.6.3 *Cruise Liner*

Cruise liners will disembark and embark passengers at the main quay adjacent to the proposed cruise terminal building.

Slide 15 – Drg. 2164

3.6.4 *Fishing Pier*

A new fishing pier will be provided on the Eastern side within the secured area of the Port. Larger fishing vessels will be accommodated at the South Western side of the Pier where dredging will be taken to a depth of -6.0mCD. The smaller vessels will be accommodated on the North Eastern side within a pontoon system where dredging will be taken to a depth of -3.5mCD. An adjacent area of 0.3 ha will be made available as a dedicated fishing yard. In all, 16 pontoon berths will be provided with fresh water and electricity available through a metered utility kiosk.

Slide 16 – Drg. 2162

3.6.5 *Nautical Centre*

Further north along that side of the development but outside of the secured area, a new nautical centre will be provided incorporating a slipway and 0.82 ha of yard space for storage and other backup facilities for small craft. This facility is well positioned as regards shelter and water depth adjacent to Renmore and Ballyloughaun Beaches. It will be made available as a public amenity.

Slide 17 – Drg. 2161 – Marina

Slide 18 – Realsim Image of Marina

3.6.6 *Marina*

A new marina for 216 boats with floating pontoons and protective breakwater will be established on the western side of the development. A dedicated yard area of 0.73 ha will be provided alongside to cater for vessels out of the water and for marine, public or show events when required.

The amenity open space areas, promenades and the marina and nautical centre referred to earlier will be outside of the port security cordon and will be accessible to public vehicular, cyclist and pedestrian traffic at all times.

3.6.7 *Buildings*

The new quays are to be constructed to a finished level of +4.7mOD while the finished floor level of the new buildings are to be set at +5.5mOD. In all four main buildings and seven ancillary buildings are proposed.

- Harbour Office
- Marina Office
- Passenger Terminal
- Harbour Company Warehouse which will be specifically for Harbour management use.
- Ancillary Buildings will comprise a Pump House, Security Building and ESB sub-stations.
- All future building either adjacent to the western marina and in yards will be subject to future planning applications, to Galway City Council.

All buildings will require foundations piled through the consolidated dredged materials previously dredged from channel, berth and turning circle excavations. Removal of material for construction of foundations will therefore be very limited and if required any surplus material will be removed to a licensed facility.

Slide No. 19 - Drg. 01/0110 – Offices

3.6.8 Harbour Company and Port Operations Offices

This four storey building with a ground floor plan area of 154 sq.m will be the control centre for the new harbour, including offices, boardroom, crisis management centre, vehicle traffic management and general administration.

Slide No. 20 – Drg. 02/0110

3.6.9 Cruise Terminal Building

This is a single storey building of internal floor area of 512 sq.m provided for the management and administration of disembarking and embarking passengers.

Slide No. 21 – Drg. 03/0110

3.6.10 Marina Management Building

A single storey building with an internal area of 270 sq.m will be for the management of the marina including security control and monitoring, management of facilities for the marina users and general administration. It will also provide services and facilities for the marina users.

3.6.11 Harbour Management Building

This building with an overall height of 8.5m and a floor area of 965 sq.m caters for both the temporary and permanent storage of all port machinery, equipment and supplies for the upkeep, maintenance and repair of port related apparatus.

3.6.12 Ancillary Buildings

In addition to the four principal buildings referred to above, a number of ancillary buildings are required:-

- 3 No. ESB sub-stations including the demolition of one existing station
- 3 No. control offices / buildings
- 1 No. foam / water and saltwater pumphouse.

3.6.13 Fire Water Storage Facility

The development also includes for a fire water storage facility.

This is to cater for the existing "Enwest" [Topaz] and proposed additional oil storage areas. It is for the storage of foam and contaminated water arising from the hosing down of those facilities in an emergency event.

Slide 22 – Drg. 2127 – Galway Harbour Yards

3.6.14 Galway Harbour Yards

A significant area of the GHE development will comprise transit yard areas. Taking account of safety, security, and control considerations, the development has been designed to provide distinct separate areas, with discrete access. The main areas comprise:- Marina, Harbour Company, Future Oil, Limestone, Security, Spent Fire Water, ESB, Scrap/recyclables, Steel/construction, Project Cargo and Nautical Centre.

3.6.15 Helipad

An area located to the North West of the proposed Marina Yard has been reserved for a helipad for search and rescue services.

3.6.16 Estate Management

Galway Harbour Company will be the Management Company for the overall development.

- All yards will be accessible by Heavy Goods Vehicles.
- Sites will be individually managed by Harbour clients under the control of the Management Company.
- Common areas will be controlled directly by the Management Company.
- The Nautical Centre and slipway will be operated and managed for amenity use by local sea sport associations in conjunction with Galway Harbour Company and Galway City Council, with Harbour Company having control of vessel movements.
- Open areas, landscaped areas and walkways which will be accessible to the public will be under the control of the Management Company for safety, security and maintenance.
- Water main, sewer, broadband, telecom, electricity supply, gas main will be maintained by the Harbour Company in conjunction with the service providers.

3.6.17 Navigation & Vessel Manoeuvring

The Harbour Master, Brian Sheridan will deal with aspects related to navigation and vessel manoeuvring in his evidence.

4 CONSTRUCTION ELEMENTS AND METHODS

Slide 23 – Realsim Plate 22 – Lagoon System

4.1 CONSTRUCTION METHOD SUMMARY

The new extension will be constructed south of the existing Galway Harbour Enterprise Park by the reclamation of land from the foreshore and seabed. This will be achieved primarily by the dredging of materials, mainly silts, sands and gravels from the seabed to form the deepened approach channel, turning area and berths and by re-using these materials to create the new reclaimed land.

In the first instance the area to be reclaimed or filled will be subdivided into separate lagoons each contained by robust wall systems. These wall systems will be constructed partly from locally imported rock fill embankments and partly from steel sheet piled walls driven into the bedrock, which will act as the permanent quay walls.

The rock embankments will be used as haul routes for dredged materials and other construction activities and will also act as the foundations for the principal permanent harbour roads and services. The lagoon walls will act as drains and will be lined on the inside with geotextile fabric to contain dredged sediments but allow drainage of dredged materials.

A revetment system or breakwater to protect the main commercial quay and the marina will comprise two zones of rock armour built on top of a vertical sheet pile wall system. The rock armour will be delivered to site by sea and unloaded directly into position.

The dredging works involving c. 1.8 million cu.m of material estimated as 98.7% of silt and 1.3% rock will be carried out by suction dredger, back hoe dredger and rock blasting and excavation, with all the dredged material reused in the filling and surcharge of the lagoons in the first instance and in the formation of the yards and working areas following consolidation.

4.2 DURATION

It is envisaged that construction of the full development would take up to 96 months to complete with Stage 1 planned over a 43 month period. During the construction period no work in water i.e. dredging, rock removal, pile driving or back hoe dredging would take place during the months of April – July of each year for environmental mitigation reasons.

The Stage 1 development will provide some of the key elements of the proposals, namely, the commercial quays for the oil and bitumen tankers, including the transfer pipelines, the quays for the cruise vessels and for general cargo vessels.

The other key elements, such as the outer port protection breakwater, the fishing pier, the nautical centre slipway and the marina will be provided in the following stages of the development.

4.2.1 Construction Sequence

- Stage 1: Access improvements along Lough Atalia Road; Quays and Berths for Cruise Liners, Oil and Bitumen Tankers and Cargo Vessels and new oil/bitumen transfer lines from the quay to the storage facilities
- Stage 2: Outer Port breakwater, rail embankment, further lagoon bunds and additional quays

- Stage 3: Marina Protection Breakwater, Fishing Pier, Slipway and Rail Access
- Stage 4: Marina Berths and Quay and Consolidation of Reclaimed Lands

4.3 ELEMENTS OF WORK INVOLVED IN STAGES 1-4

Nineteen separate elements of work involved in the various Stages are set out below. For illustration purposes only, a start date for construction is assumed as the month of January, albeit this may occur at any time in the year. Regardless of the date of commencement, no work in water involving dredging, rock removal, pile driving or back hoe dredging, can take place in the months of April to July inclusive for the duration of the works.

4.3.1 Construction Elements Sequencing – Stage 1

Slide 24 – Element 1 – Drg. 2145

- The first month, January of Year 1 will see the establishment of the construction site compound and mobilisation of construction machinery.

Slide 25 – Element 2 – Drg. 2145

- Enabling works involving a junction upgrade at the entrance to the Harbour Company property adjacent to the Harbour Hotel and at Lough Atalia Road Rail Bridge will be undertaken during months 1 and 2.

Slide 26 – Element 3 – Drg. 2145

- In March of Year 1 a haul road which will define the North Eastern boundary of the site adjacent to Renmore beach will be constructed for approx. 400m Southwards out across the foreshore. This will be formed from imported rock fill.
- No work would be carried out in water in the months of April to July inclusive, but other work not affecting water would be continuing.

Slide 27 – Element 4 – Drg. 2146

- Over the months August to October work would continue on construction of haul roads to form the first two enclosed lagoons Nos. 1 and 2. The internal faces of the lagoons will be lined with geotextile, allowing for the drainage of water out of the dredged materials but controlling the leakage of sediments out of the lagoons.

Slide 28 – Element 5 – Drg. 2146

- Over the months of October and November of Year 1, work commences on the dredging operations.
- The dredging of a new channel to the existing docks would be undertaken in the first instance with the dredged material pumped to and placed within lagoons 1 and 2.
- This will allow for continued access to the existing inner docks and so permit work to be carried out across the existing channel.
- Dredging by trailer suction dredger, rock blasting and excavation of blasted rock by back hoe dredger for the foundations for the sheet piled walls of the marina will then be undertaken.

Slide 29 – Element 6 – Drg. 2146

- Over the next 5 months [i.e. November Year 1 to March Year 2] further haul roads to develop lagoons 3 and 4 would be constructed.

In addition, part of the sheet piled wall to the marina would be installed.

- Again as with Year 1, no work in water would be undertaken during the months of April-July inclusive of Year 2, but again work not affecting water would be continuing.

Slide 30 – Element 7 – Drg. 2147

- On resumption of work in August of Year 2, dredging of the soft upper seabed material would commence at the berths, turning circle and access channel locations using trailer suction hopper dredger. Dredged materials would be pumped to lagoons 3 and 4 and would continue up to November of that year.

Slide 31 – Element 8 – Drg. 2147

- From November up to March of Year 3 lagoon 5 would be created by the construction of a further haul road.

The sheet pile marina wall would be extended to partly close an area for lagoon 6. During the same period ca. 180m of the main quay would be constructed to facilitate berthing of ships carrying construction and dredge materials.

- Work in water would again be suspended for the months of April to July, inclusive of Year 3.

Slide 32 – Element 9 – Drg. 2148

- From August to October of Year 3, work on dredging the firm lower seabed material at the berths, turning circle and access channel would be undertaken using a backhoe type dredger with the material to be placed in lagoons 1-6.

Slide 33 – Element 10 – Drg. 2148

- A further 420m section of the main quays would be constructed during this period. At the same time the installation of vertical band drains into the materials placed within the various lagoons to assist in consolidation would be undertaken.

During this period also, the chamber system to house the oil and bitumen lines would be installed within the haul road, which forms the main spine road through the development.

This would essentially complete Stage 1 of the development, thus providing the commercial quays for the oil and bitumen tankers [including the transfer pipelines], the quays for the cruise vessels and for general cargo vessels.

Slide 34 – Stage 1 Completion – Realsim Plate 21

- This image shows the Stage 1 development, with the main berths and quays largely in place, the 6 No. lagoons filled and consolidating and the main spine access road containing the transfer pipelines in place.
- As in previous years, work in water is suspended for the months of April to July inclusive.

4.3.2 Stage II

Slide 35 – Element 11 – Drg. 2149

- Work on Stage II to be undertaken in the months of August to December [i.e. months 44-48 from commencement] would include the completion of the final 60m of the 660m quays and the provision of the 260m long outer breakwater.

Slide 36 – Element 12 – Drg. 2149

- From December of Year 4 to March of Year 5 the final lagoon No. 7 is formed by the construction of the seaward wall to the West of the main quays.

The railway embankment and associated road under-pass to the Eastern Enterprise Park would be constructed during this period.

Slide 37 – Realsim Plate 22

- This is the completion of Stage II and shows the full length quays, the outer breakwater and the enclosure to lagoon No. 7.
- No work will be undertaken in water during the months April to July inclusive of Year 5.

4.3.3 Stage 3

Slide 38 – Element 13 – Drg. 2150

- Work will resume in August of Year 5 [i.e. month 56 from commencement] with the dredging for the fishing pier, the marina berths and the access channel to the marina. The dredged material would be placed into lagoon No. 7.

In addition surplus consolidated material placed in lagoons 1-6 as surcharge to aid consolidation would be stripped and placed into lagoon No. 7 also.

Slide 39 – Element 14 – Drg. 2150

- From September of Year 5 to March Year 6 the breakwater would be constructed. This will complete the work in water so that work will continue on other elements of the development.

Slide 40 – Element 15 – Drg. 2151

- This element to be carried out from March-July of Year 6 involves continuing capping of the Stage I lands, including the provision of services and completion of roads.

Slide 41 – Element 16 – Drg. 2151

- From August Year 6 to February Year 7, work would be undertaken for the installation of the rail line, the nautical centre slipway and the fishing pier.

Slide 42 – Element 17 – Drg. 2152

- The Passenger Terminal Buildings and Harbour Warehouse and the development of yards on the Stage I lands would be undertaken in the period February to September of Year 7 i.e. months 74-81 from commencement.

This completes Stage III of the development as can be seen from Plate 23.

Slide 43 – Realsim Plate 23

4.3.4 Stage 4

Slide 44 – Element 18 – Drg. 2152

- This element sees the completion of the capping of lagoon No. 7 towards the end of Year 7.

Slide 45 – Element 19 – Drg. 2153

- The marina fit out, marina management building and harbour office would be provided over the course of Year 8. At the same time the further development of the various yards and lands would be undertaken.

Slide 46 – Realsim Plate 24

- This plate shows the completed development following the 8 year, 4 stage construction programme.

Slide 47 – Realsim Model View 2

Slide 48 – Realsim Model View 4

Slide 49 – Realsim Model View 5

4.4 CONSTRUCTION METHODS

4.4.1 Site Investigations

In order to design the proposed port structures, geotechnical investigations were commissioned to establish the profile and nature of soils and underlying bedrock across the proposed site. The investigations generally showed soft silts, becoming firmer with depth, overlying bedrock. Close to the existing shoreline, there are some sands and gravels above the bedrock. The investigation results provide the information to facilitate the design of the foundations for the proposed quay and breakwater structures. The investigation results also provided information in relation to selection of the port infrastructure location and orientation, potential for re-use of excavated materials and to allow construction contractors plan appropriate methodologies and select appropriate equipment.

Slide 50 – Fig. 4.5.1 – Stage 1 – Lagoon Wall Construction

4.4.2 Lagoon Wall Construction

To facilitate the controlled reclamation of land for use as yards, access roads and other port back-up facilities, the land reclamation areas will be divided into seven discrete lagoons. Six of these lagoons will be constructed during Stage 1 and Lagoon 7 during Stage 2. The stages of construction of these was covered earlier. In order to contain these areas, which will be formed in discrete stages, lagoon wall structures will be constructed, which will act firstly as containment structures for the discrete lagoons. The walls or embankments provide access for general construction equipment and haul roadways for construction material deliveries and excavated material movement. In this regard, it should be noted that much of the material to form these walls, in particular the rock armour revetment, will be delivered to the site by sea, and placed into position by crane. It should be noted that these walls, in common with the lagoon filling, will be constructed initially to 2 metres above final ground level, to provide for surcharging of the fill and bed materials and consolidation of these over time.

Slide 51 – Fig. 4.5.2 EIS Chapter 4 – Lagoon Wall Construction

The lagoon wall construction is generally similar everywhere but may have a different construction on one side or the other, depending on whether it will be exposed to the sea, is an internal lagoon wall or is adjacent to the shipping channel or marina.

Prior to construction of the lagoon embankment walls, any soft silty materials on the sea bed will be removed, to provide a firm substrate upon which to construct the lagoon containment embankment walls. The core material of the embankment walls will comprise imported crushed rock ranging in size from 150mm down to 50mm to provide a stable embankment core. This core structure is designed to retain the dredged material being deposited into the lagoons. In order to retain the fine sediment, the internal faces of the core material will be lined with a heavy-duty geo-membrane. The geo-membrane will allow water, transported and deposited with the

dredged sediments, to drain away through the textile and out of the lagoon, while retaining the fine sediments, and thereby facilitating consolidation of the deposited sediments over time. On the seaward exposed faces, rock armour revetment will be built up in two layers. The revetment is designed to protect the core material from damaging sea wave action. The inner secondary layer will comprise typically 300mm size imported crushed rock. This acts as a stable bed for the outer primary rock armour, as well as an intermediate layer between the relatively smaller core material and the large size armour rock. The outer primary armour rock will comprise a minimum of two layers of typically 2 tonne boulders, designed to withstand the wave heights provided by the wave climate study. Berms will be formed to provide stability at the base of both the internal face rock core material, and the outer exposed face rock armour. To prevent scour attack from undermining the toe of the seaward exposed face, both primary and secondary rock armour revetment will be founded on bedrock.

The top of the facing rock will be brought approximately 0.5m above the top level of the lagoon walls, to create an edge kerb there. The general level of the lagoon walls will be brought to 6.7m OD. This is some 3.86m above highest astronomical tide, thus facilitating drainage / consolidation of the surcharged dredged materials. This level will prevent overtopping of the lagoon walls by sea waves for the design conditions provided by the wave climate study.

Slide 52 – Fig. 4.5.12 Deepwater Quays

Slide 53 - Fig. 4.5.14 Quay Wall Construction

4.4.3 Quay Wall Construction

The outer port comprises a deepwater berth for commercial shipping and cruise liners. These quay structures have been designed using rock fill contained between two lines of the vertical sheet pile combiwall system.

This system incorporates interlocking steel sheet piling integrated with intermediate tubular steel piles. The tubular steel sections will be installed approximately 2.0 to 2.5m into the existing bedrock. To facilitate this, a trench some 2m wide by 2m deep will be pre-blasted into the bedrock. Once the upper larger fractured material has been excavated, the piling system will be driven into the fractured bedrock.

The tubular pile element of the system will be positively anchored at the base by drilling and grouting into the rock.

A cohesive colloidal cement grout will be injected down through the tubular piles into the blasted rock-filled trench at the base of the pile, to provide lateral restraint to the toe of the pile system. Notwithstanding the use of special colloidal grout, which minimises mix separation and dispersion in water, an additional barrier of a double layer of interlocked sand bags will be placed along the top of the rock-filled trench each side of the piling system, and the sand bags in turn will be covered in crushed rock ballast. This sand bag capping to the trench will provide a top seal to prevent grout escaping into the water column. The grout injection operation will be monitored by divers to provide assurance on the effectiveness of the grout barrier.

The area between the vertical sheet piling will be excavated down to bedrock level. This will then be filled with imported rock fill, typically size 150mm to 50mm. As the fill progresses, steel anchor tie systems will be installed to contain the rock fill lateral pressure and provide an integrated quay structure comprising the two lines of steel sheet piling acting together with the structural rock fill. The integrated structure is complete when the reinforced concrete deck is constructed. This integrated structure is designed to withstand the operational loadings due to ship berthing forces and material/equipment superimposed loadings, as well as environmental loadings due to wind and wave.

On the outer 260 deepwater quay a reinforced concrete wave wall to a height of 10.1m OD is proposed. This wave wall is designed to deflect wave run up, prevent wave overtopping and minimise wave splash onto the quay working area. The wave wall will be pre-fabricated in sections and installed in final position by crane and cast in with the quay structural slab.

Slide 54 – Fig. 4.5.15

4.4.4 Commercial Port Breakwater Design

The Deepwater berths are designed to provide a safe haven for large commercial shipping and tourist liners. The climate wave studies identified the need for a breakwater to be provided extending broadly Eastwards from the outer end of the 260m quay, in order to provide protection from the sea state for shipping berthing at the Deepwater Berths.

This breakwater is similar in construction to the quay structures, comprising two vertical steel sheet piled containment walls filled with rock fill, and incorporating walings, anchor ties and temporary bracing. The vertical wall elements extend up to 5.17mOD. The vertical elements are required to contain the breakwater within the same confines as the 260m deepwater quay, to protect the shipping channel. Above that level, sloped rock armour will be extended up to 10.1mOD, similar to the rock armour construction describe earlier, but with 10 tonne primary layers on 1 tonne secondary layers, all designed to withstand wave exposure for that area identified by the wave climate study.

4.4.5 Nautical Slipway Design

The Nautical Slipway design comprises a precast concrete slab in the main, laid at a gradient of 1 in 15. This will be laid on engineered stone fill, in turn laid on the existing dense granular subgrade or bedrock. Any local pockets of soft material will be excavated prior to placement of the stone filling. The end of the slipway will be formed using bagged concrete using a sealed proprietary system. The sides of the slipway will be protected by rock armour bedded on bedrock or solid subgrade that will not be susceptible to wave scour.

4.4.6 Fishing Pier Design

The Fishing Pier has been designed using a double steel combiwall system filled with rock fill materials laid on excavated bedrock, similar to the deepwater quay design principles and with a reinforced concrete deck slab.

4.4.7 Kayak Steps Design

In addition to the multiple amenities to be provided as an integral part of the new port development, water sports enthusiasts identified the need for an access point for kayak and similar water sports users. The provisions will comprise a series 6 metre wide steps formed in concrete, to allow kayaks to come alongside and disembark at various stages of the tide. These will be located in the relatively protected zone between the Fishing Pier and the Nautical Slipway

4.4.8 Marina Design

The Marina is proposed to be located towards the inner end of the new port and adjacent to the inner port shipping channel. The Marina will comprise a system of floating pontoons and walkways, constructed in fibre reinforced concrete. The pontoons and walkways will be furnished with conventional hardwood anti-slip decking, hand rails, ladders, mooring cleats, deflectors, water and power connections. The pontoons and walkways will be held in

position using conventional tubular pile guides, the piles being driven and keyed into bedrock.

The Marina will also incorporate a quay at the South end of the Marina. This will be constructed using the rock filled combiwall system similar in design to the Fishing Pier.

4.5 DREDGING WORKS

Based on the borehole investigation carried out by Causeway Geotechnical, the sediment dredging quantities are estimated at 1.815 million cu.m for the entire development with majority of 1.705 million cu.m arising in the Stage 1 works.

All dredged material will be used as fill for the proposed reclamation area. Consequently, no material from dredging during construction will be disposed of at sea. The main types of dredgers to be used will be (i) trailer suction hopper dredger (TSHD) for the upper softer layers, initial quay wall and breakwater foundation clearance and dredging of the new channel to existing port and (ii) backhoe dredger for the lower stiffer layers.

Slide 55 – Figure 4.5.8 – Dredging Locations

4.6 TRAILING SUCTION HOPPER DREDGER [TSHD]

A trailing suction hopper dredger [TSHD] is a sea-going self-propelled ship, suitable for the dredging of unconsolidated material, such as silts, sands and weak clay. Such vessels can discharge by bottom dumping methods or by hydraulically pumping ashore via a pipeline system; only the latter method is proposed for this development. The TSHD is equipped with one or two suction pipes, designed to hang along the side of the vessel. A draghead is fixed at the lower end of the suction pipe, which is then moved along the bottom of the seabed. Suction is provided by a pump, which lifts the material off the seabed and discharges the mixture of dredged material and water into the hopper well.

The TSHD will be used to dredge the top layer of weak seabed material for the initial quay wall, the breakwater clearance and the new channel to the existing docks. This dredged material will be pumped into the various Lagoons.

Once the TSHD is full with dredged material, it will proceed to the vicinity of the lagoons, connect to a sealed floating pipeline there and then pump the dredged material from its hold / hopper via the pipeline into the lagoons on a rotational basis, depending on the stage of filling achieved in each lagoon.

Slide 56 – Figure 6.7.2 – Typical Trailer Suction Hopper Dredger

Slide 57 – Figure 6.7.3 - TSHD pumping onshore via floating pipeline

4.7 BACKHOE DREDGER

It is proposed to use a backhoe dredger to dredge deeper firmer materials. The dredged material will be excavated and loaded to a barge. When full the barge will pull up alongside the initially constructed section of commercial quay. Another backhoe excavator will remove the dredged material from the barge into dump trucks parked on the quay. These will transport the material to the Lagoons.

The backhoe dredger system incorporates a purpose built pontoon, mounted with a large marine excavator. The dredger is not self propelled and will be towed to site. The sediment transport barges will be self-propelled.

Slide 58 – Fig. 4.5.11

4.8 ROCK DREDGING

The overall configuration of the development has taken account of the geological conditions beneath the sea bed and has been designed to reflect the rock contours to minimize the quantities of rock to be removed.

Approx., 24,000 cu.m of rock will be excavated, with 10,000 cu.m arising from providing the required depth at the northern end of the 400m cruise liner berth and a further 14,000 cu.m from the trenches to be excavated to accept the sheet piled walls for the various quays. The total of rock excavation amounts to 1.3% of the overall quantity of material to be excavated.

The dredged rock will be re-used in the formation of revetments, breakwaters and haul roads.

AN BORD PLEANAITHE
 TIME 10.15. BY *Grainy*
 13 JAN 2015
 LTR-DATE *14*
 IN *R00033*



Overall Development

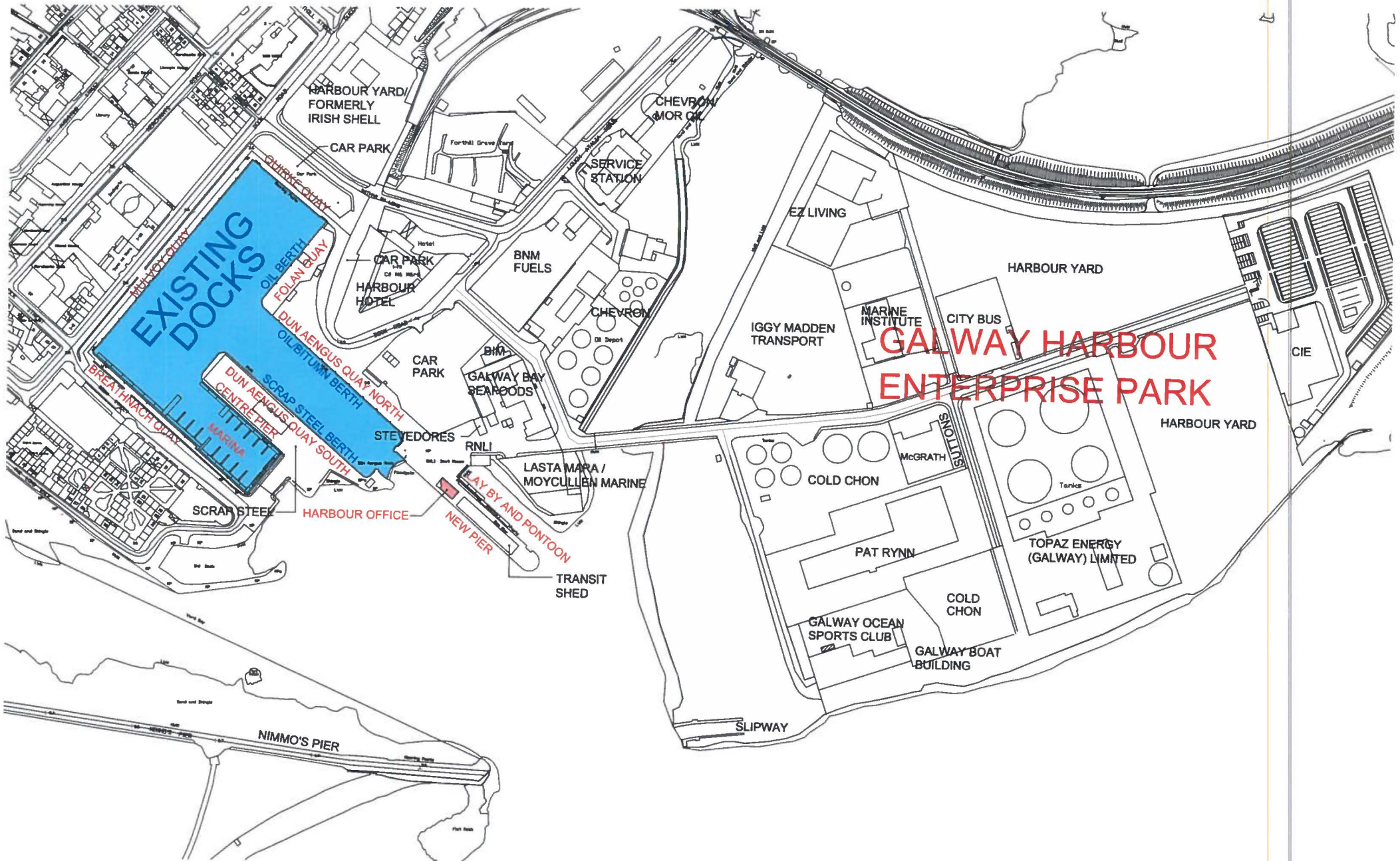

Existing Docks and GHEP

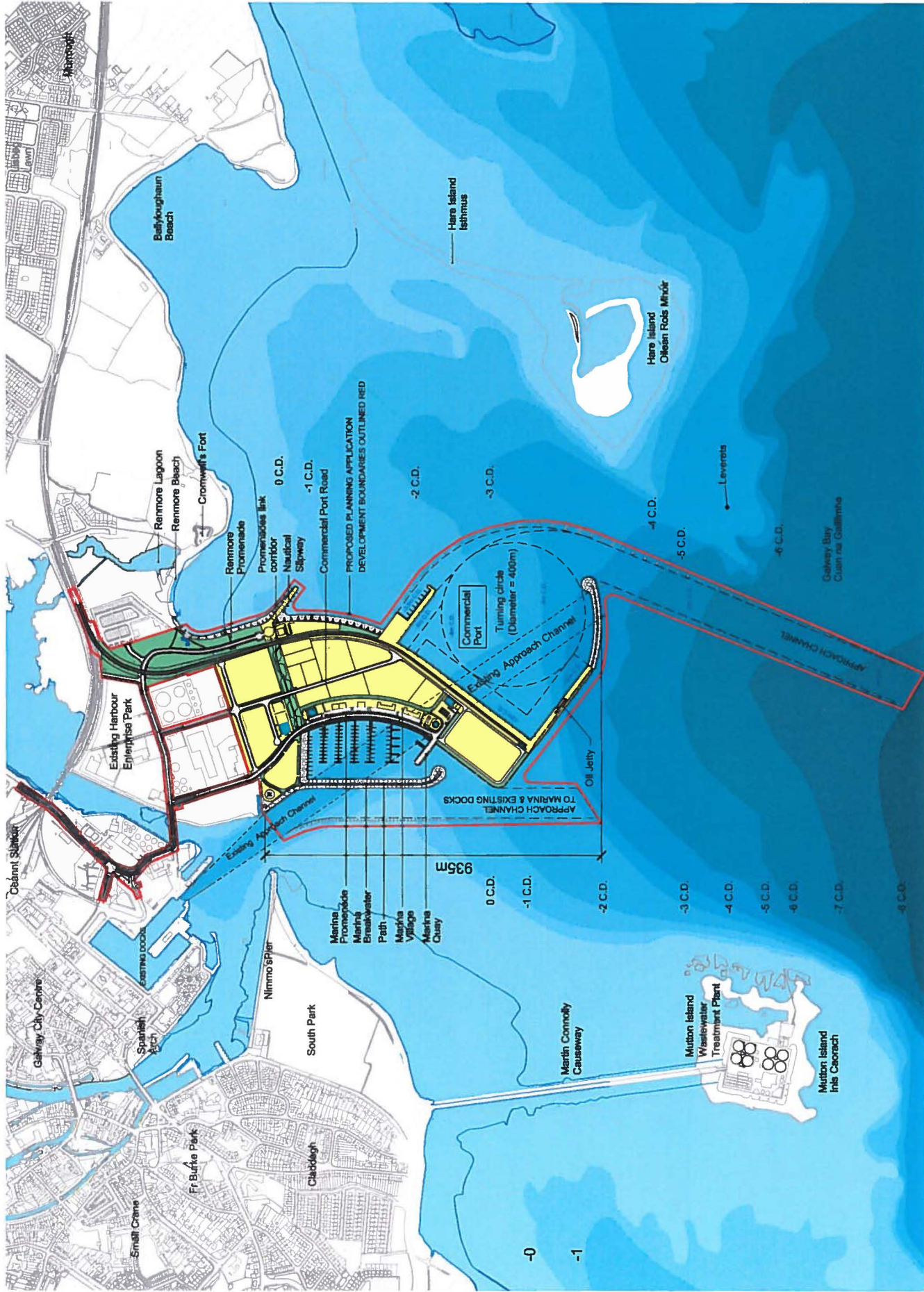

Site Layout Map

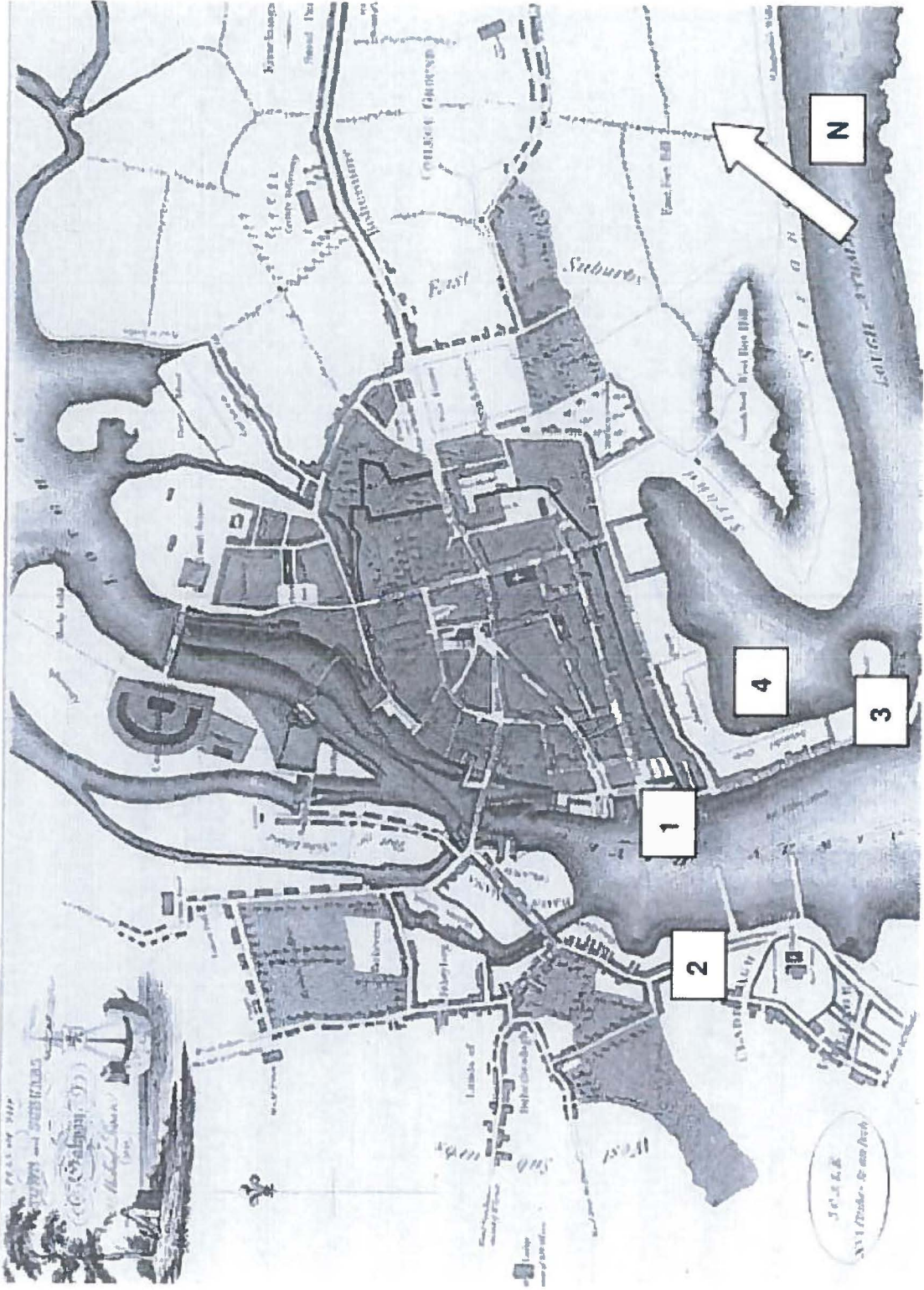

1820 Map of Galway

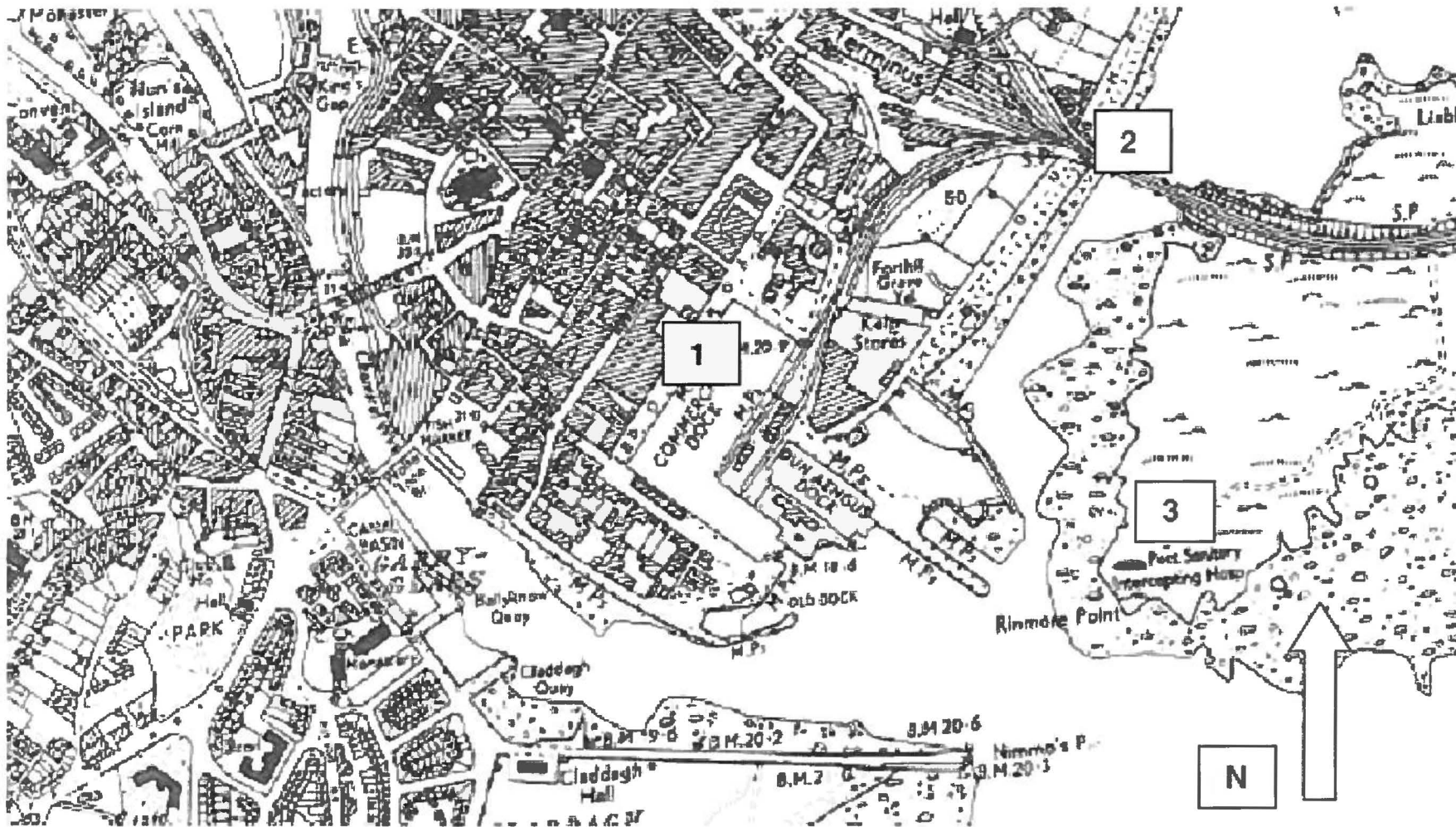

1945 Ordnance Survey Map of Galway

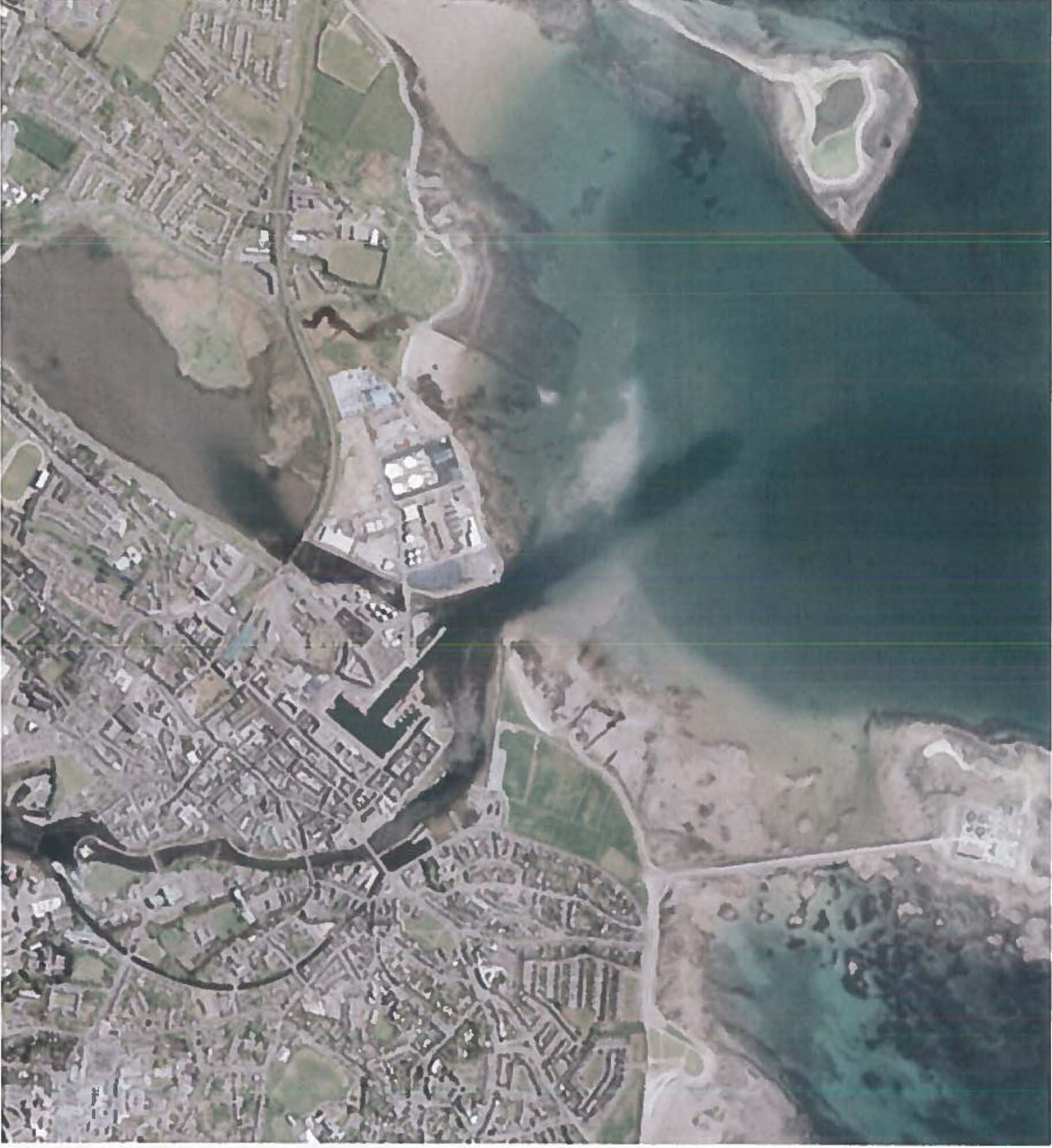

2011 Aerial Photo of GHEP



Jumbo Spirit entering Galway Docks

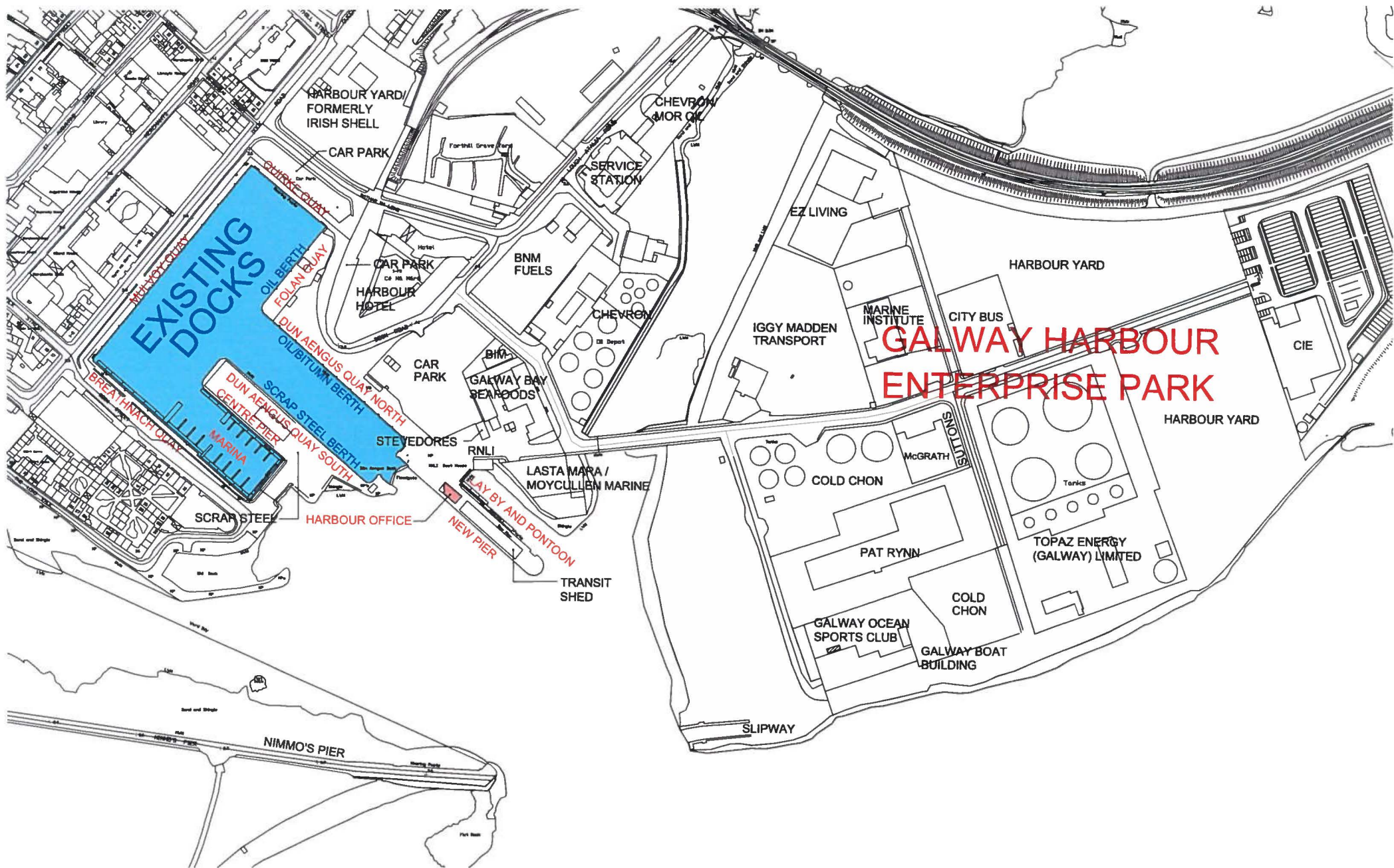

**GALWAY HARBOUR
ENTERPRISE PARK**

Existing Docks at GHEP

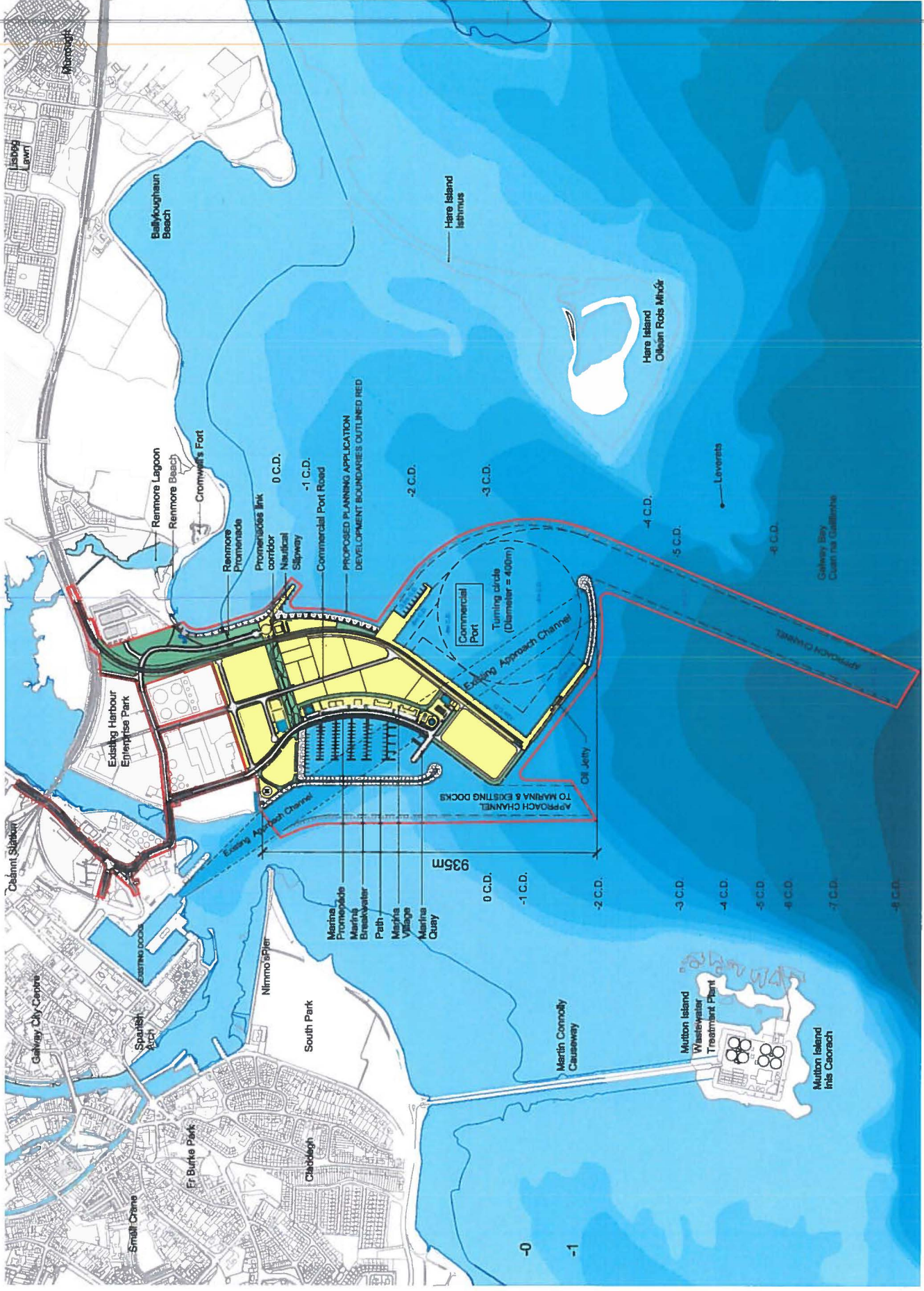

Site Layout Map

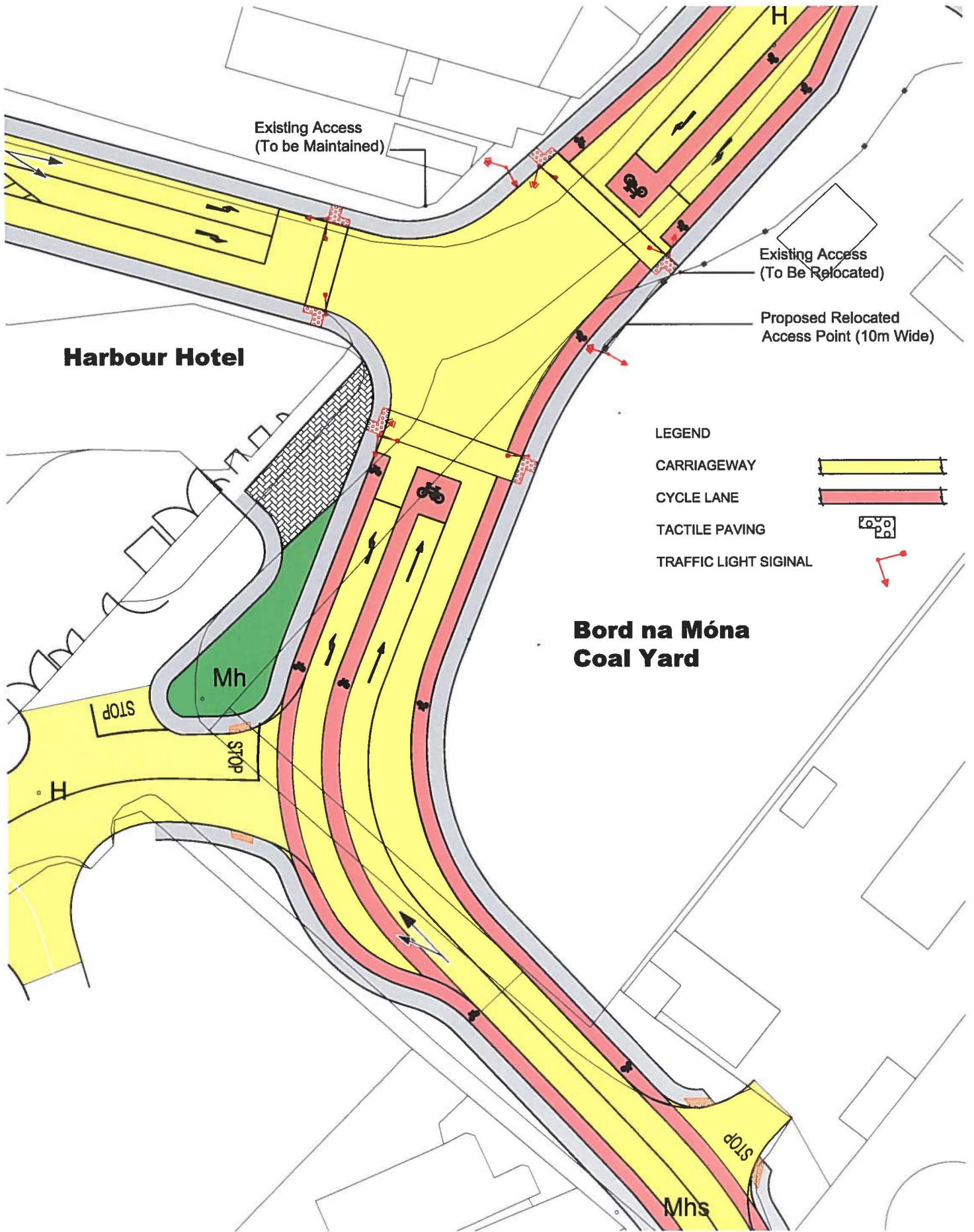

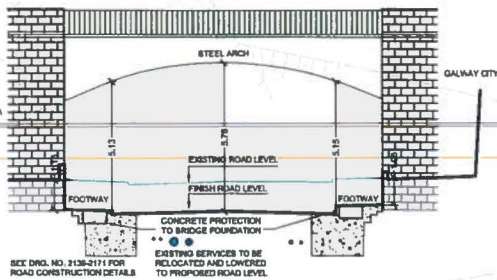

PROPOSED NORTH EAST ELEVATION SCALE A3 1/200

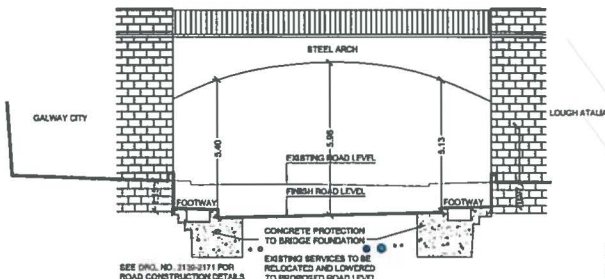

PROPOSED SOUTH WEST ELEVATION SCALE A3 1/200

NOTE:
 Pedestrian Guardrail to be provided along top of Retaining Wall where level difference exceeds 1.0m high. Guard Rail to be extended to where level difference is less than 600mm

Landscaping to Galway City Council's Requirements to be provided in this area. (North West Quadrant)



Retaining Wall 1.2m high tapering to 0.0m shown highlighted blue. 1.2m wide working area to be reinstated where disturbed during construction of retaining wall

Retaining Wall 1.2m high tapering to 0.0m shown highlighted blue. 1.2m wide working area to be reinstated where disturbed during construction of retaining wall

Road centreline and associated chainage of road lowering shown highlighted Red

Advisory On-Road Cycle Lane under bridge

Advisory On-Road Cycle Lane under bridge

Retaining Wall 1.2m high tapering to 0.0m shown highlighted blue. 1.2m wide working area to be reinstated where disturbed during construction of retaining wall

Road chainage and associated chainage of road lowering shown highlighted Red

Retaining Wall 1.2m high tapering to 0.0m shown highlighted blue. 1.2m wide working area to be reinstated where disturbed during construction of retaining wall

Existing kerbline at site entrance to be repositioned and regraded to suit new road layout

Abutment

Abutment

Abutment

Abutment

FOOT PATH
CYCLE TRACK

FOOT PATH
CYCLE TRACK

FOOT PATH
CYCLE TRACK

FOOT PATH
CYCLE TRACK

Pr 5.782
Ex 5.782

Pr 5.566
Ex 5.571

Pr 5.433
Ex 5.411

Pr 5.210
Ex 5.242

Pr 4.895
Ex 5.068

Pr 4.490
Ex 4.893

Pr 3.995
Ex 4.675

Pr 3.620
Ex 4.461

Pr 3.175
Ex 4.238

Pr 2.932
Ex 4.074

Pr 2.800
Ex 4.022

Pr 2.779
Ex 4.054

Pr 2.869
Ex 4.100

Pr 3.070
Ex 4.162

P 3.383
Ex 4.264

Pr 3.806
Ex 4.407

Pr 4.242
Ex 4.578

Pr 4.577
Ex 4.768

Pr 4.813
Ex 4.901

Pr 4.949
Ex 4.964

Pr 4.998
Ex 4.998

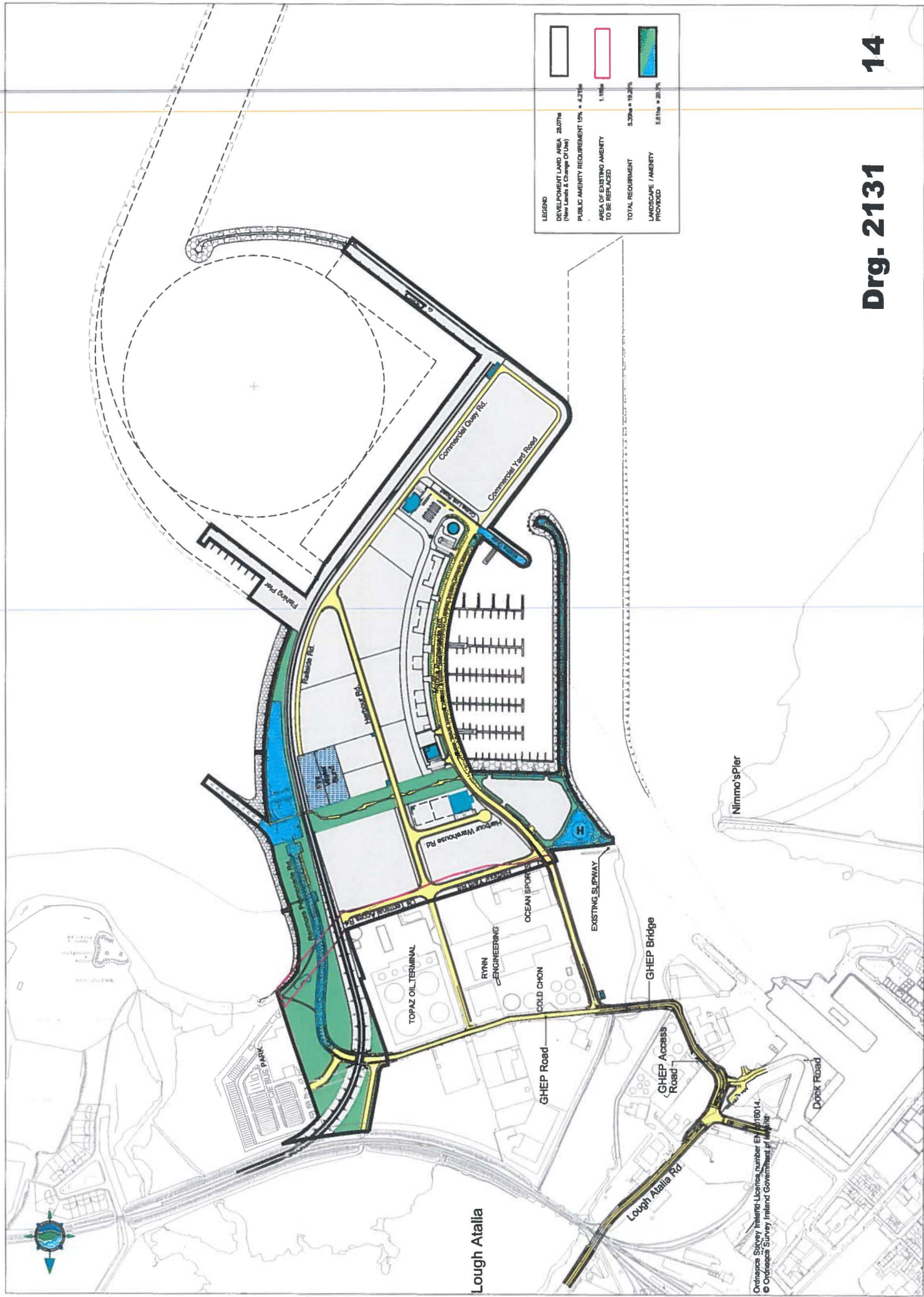

LEGEND

	DEVELOPMENT LAND AREA 28,07ha (New Lands & Change Of Use)
	PUBLIC AMENITY REQUIREMENT 10% = 4,21ha
	AREA OF EXISTING AMENITY TO BE REPLACED 1,1ha
	TOTAL REQUIREMENT 5,32ha = 19,2%
	LANDSCAPE / AMENITY PROVIDED 5,81ha = 20,7%

Ordnance Survey Ireland Licence Number EN18014.
© Ordnance Survey Ireland Government of Ireland

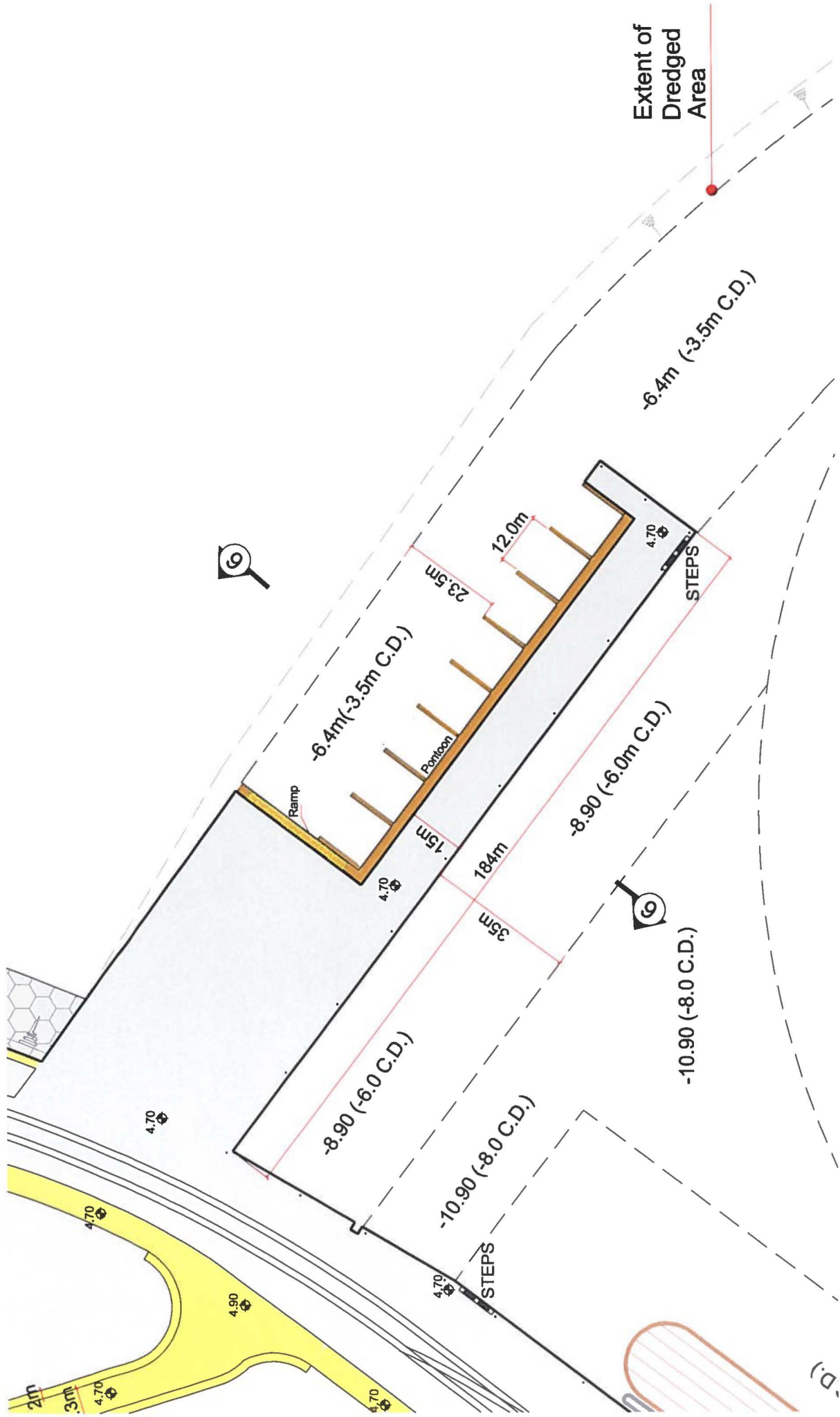

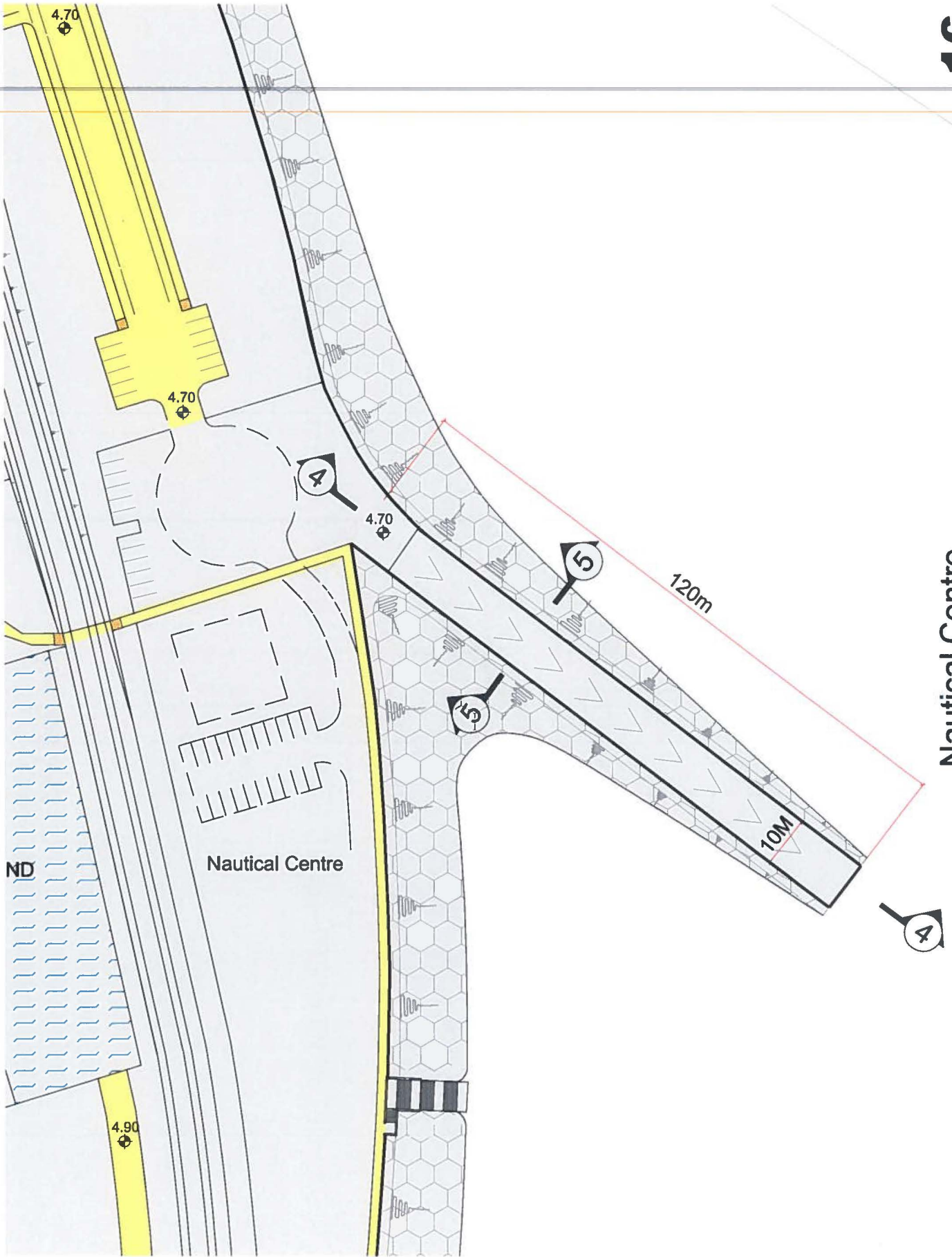

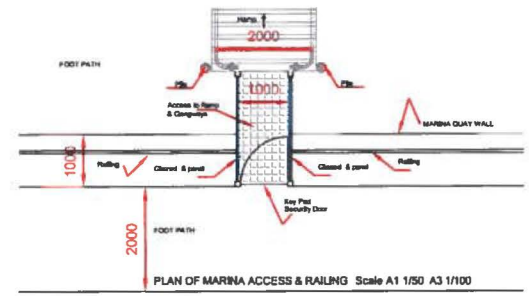
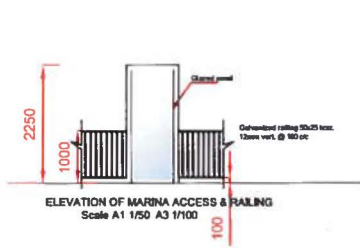
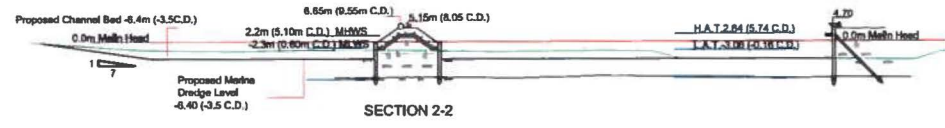
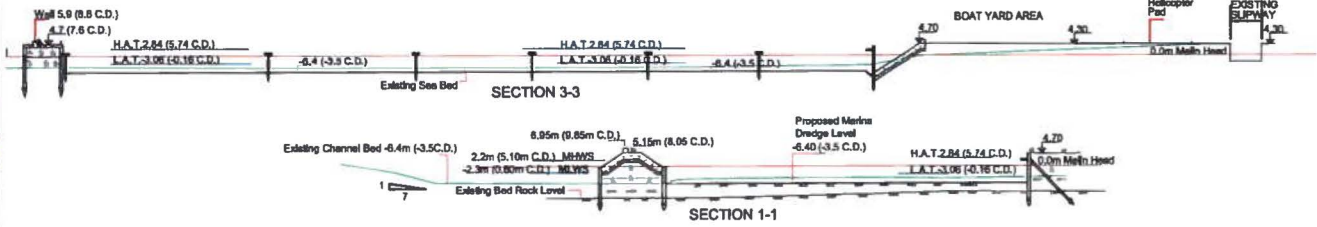
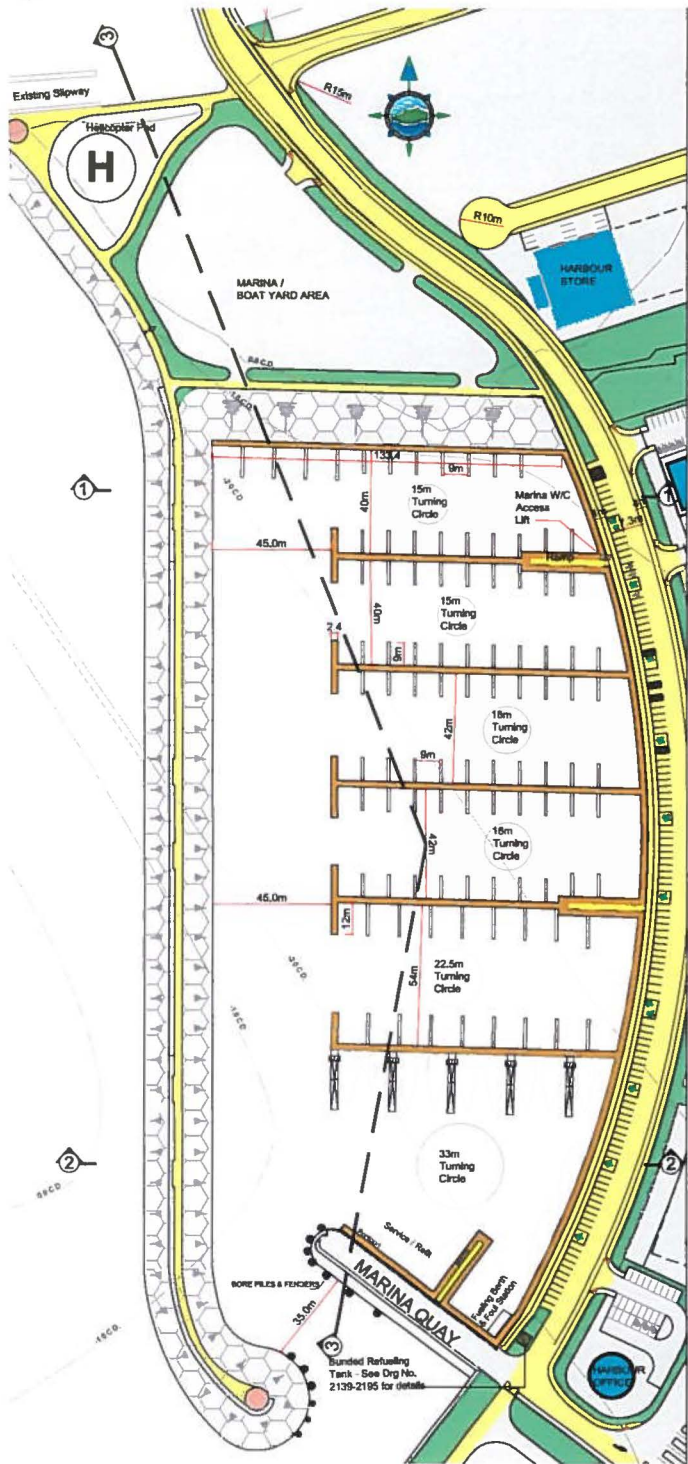

LEGEND	
FRESH LEVEL AND MARK	4.20
SEA BED CONTOUR	SEA BED CONTOUR (-3.5 C.D.)
ROADS / PATHS	Yellow line
LANDSCAPE AREA	Green area
SERVICE BUILDINGS	Blue area

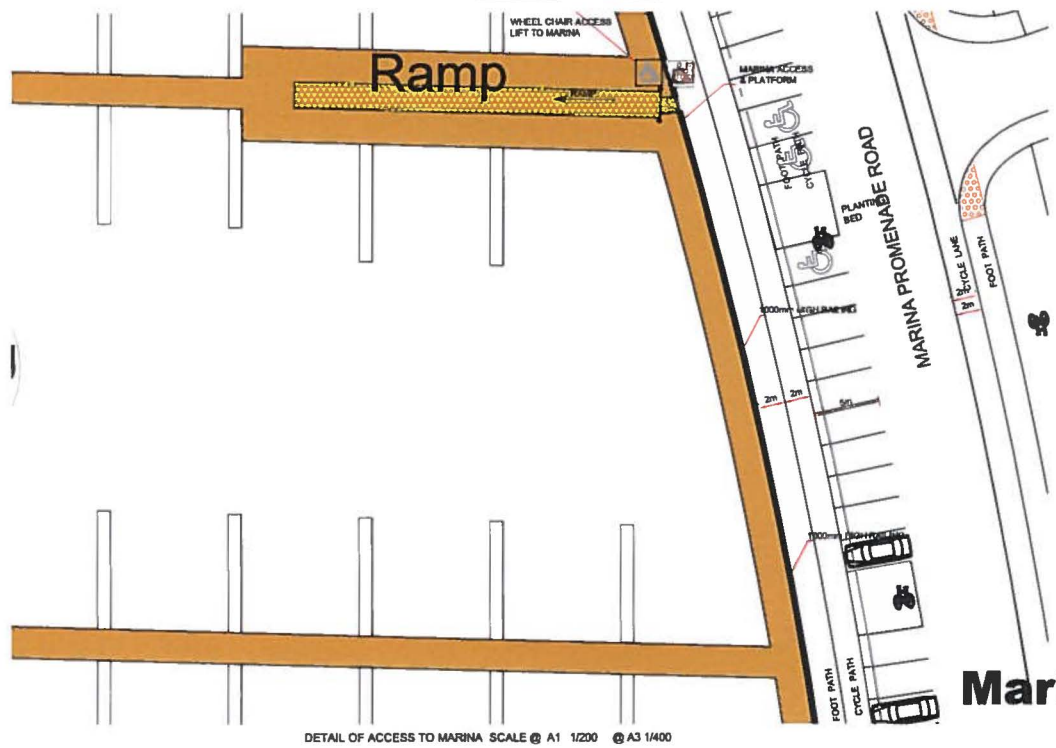



Marina

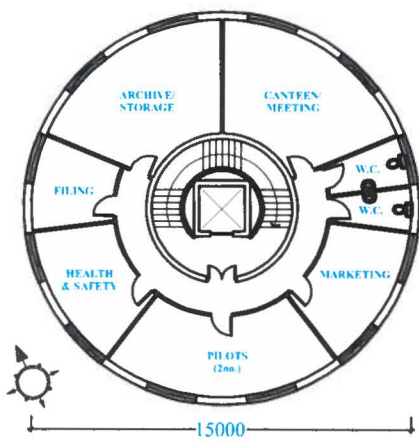

FIRST FLOOR PLAN
177m²

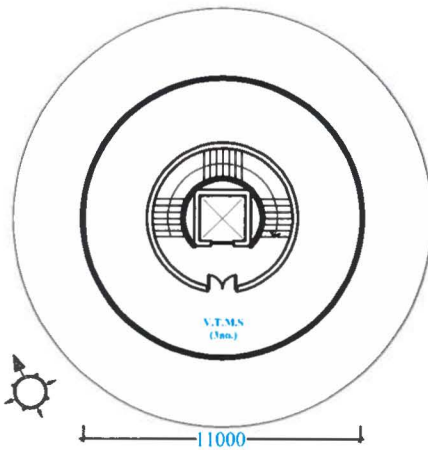

THIRD FLOOR PLAN
113m²

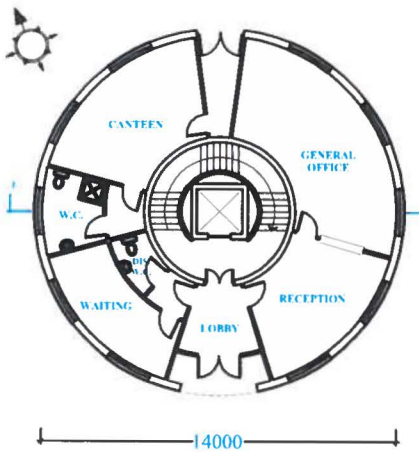

GROUND FLOOR PLAN
154m²

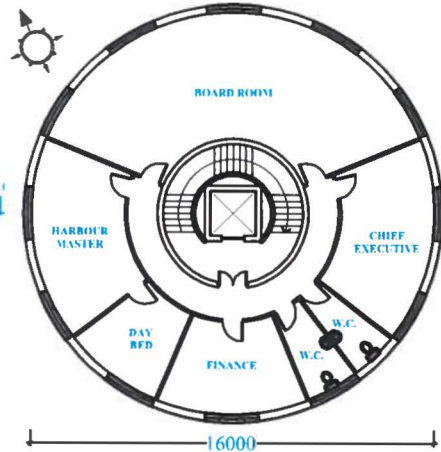

SECOND FLOOR PLAN
201m²

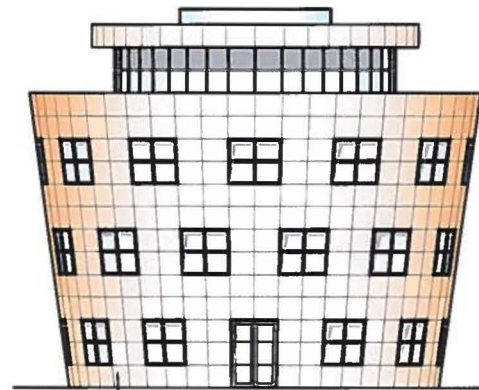

REAR ELEVATION

Tripsa flat rainscreen facade panel finish, colour: rust.

Triple glazed aluminium screens and windows with black powder coated finish.



FRONT ELEVATION

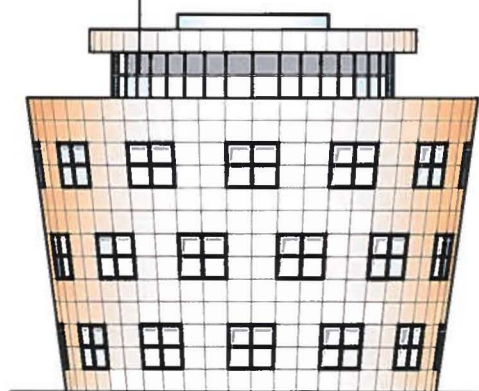

SIDE ELEVATIONS

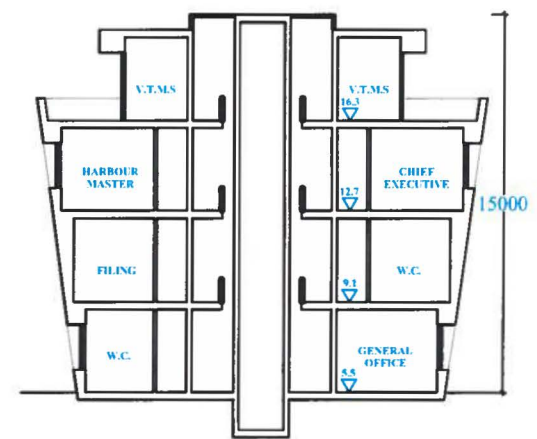

SECTION A-A

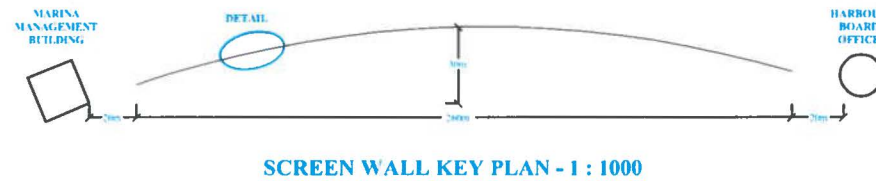
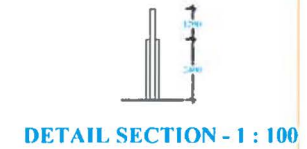
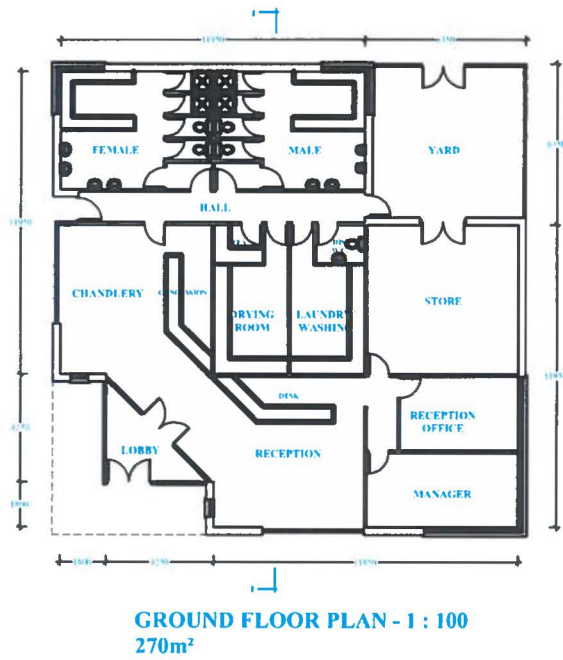
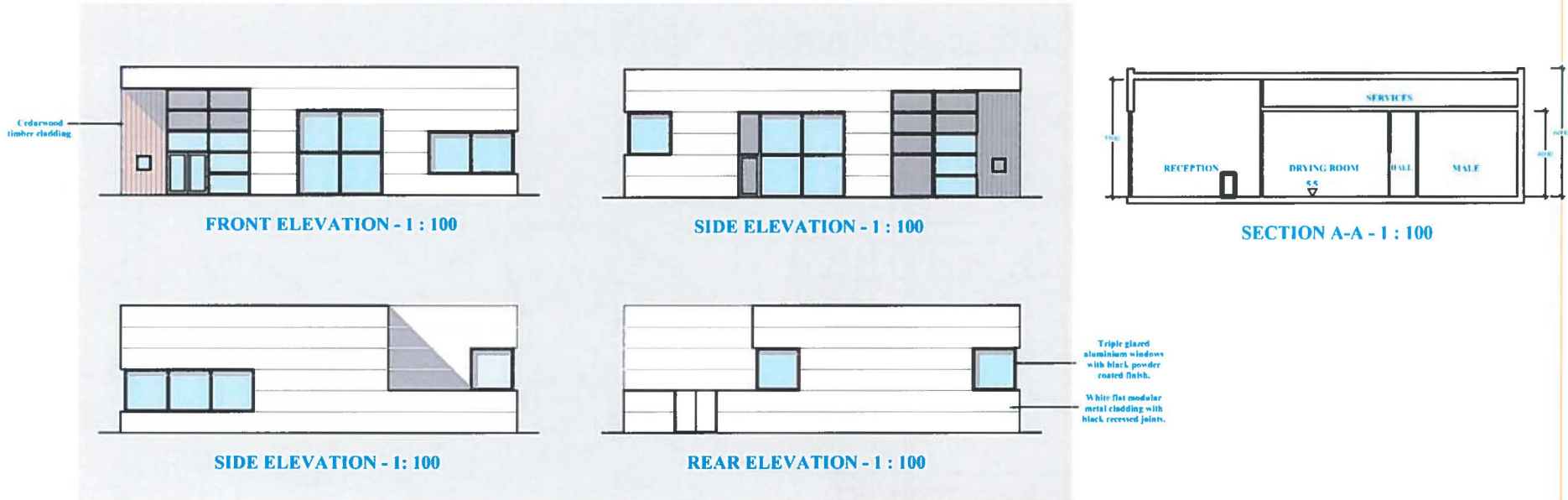

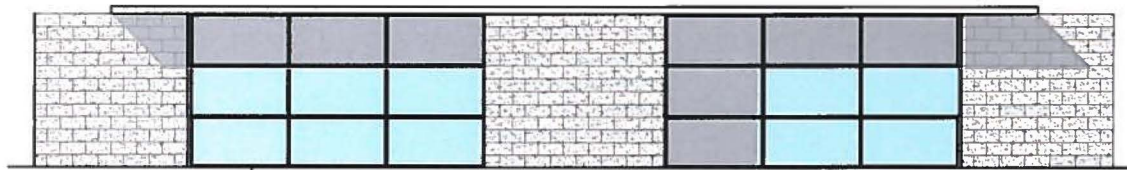

FRONT ELEVATION - 1 : 100

Triple glazed aluminium curtain walling with black powder coated finish.

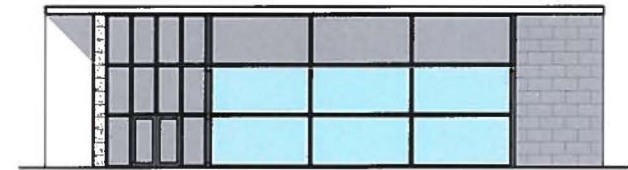

SIDE ELEVATION - 1 : 100

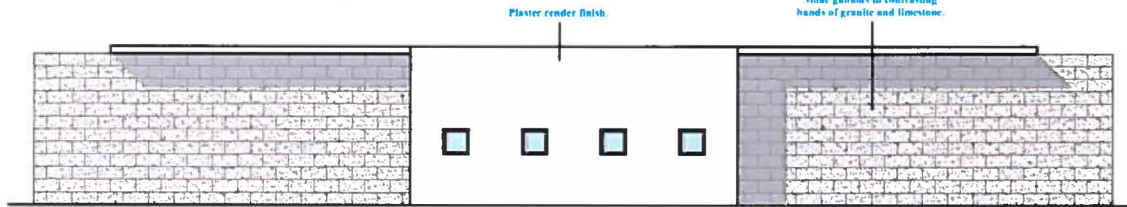

REAR ELEVATION - 1 : 100

Plaster render finish.

Stone gables in contrasting bands of granite and limestone.



SIDE ELEVATION - 1 : 100

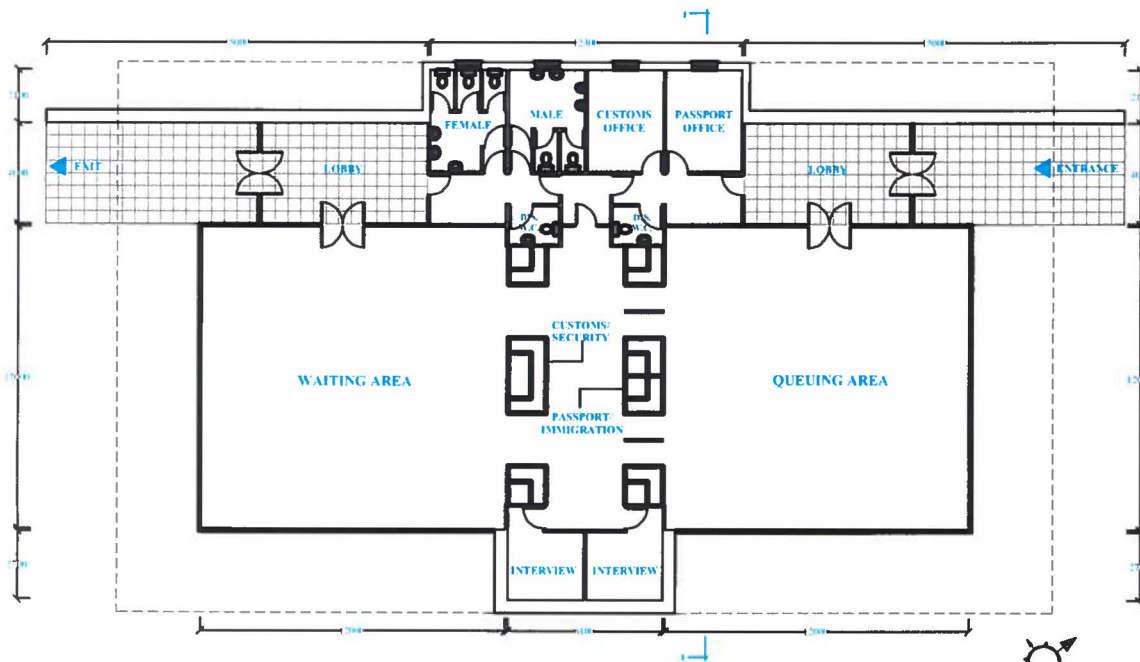

GROUND FLOOR PLAN - 1 : 100
512m²



SECTION A-A - 1 : 100

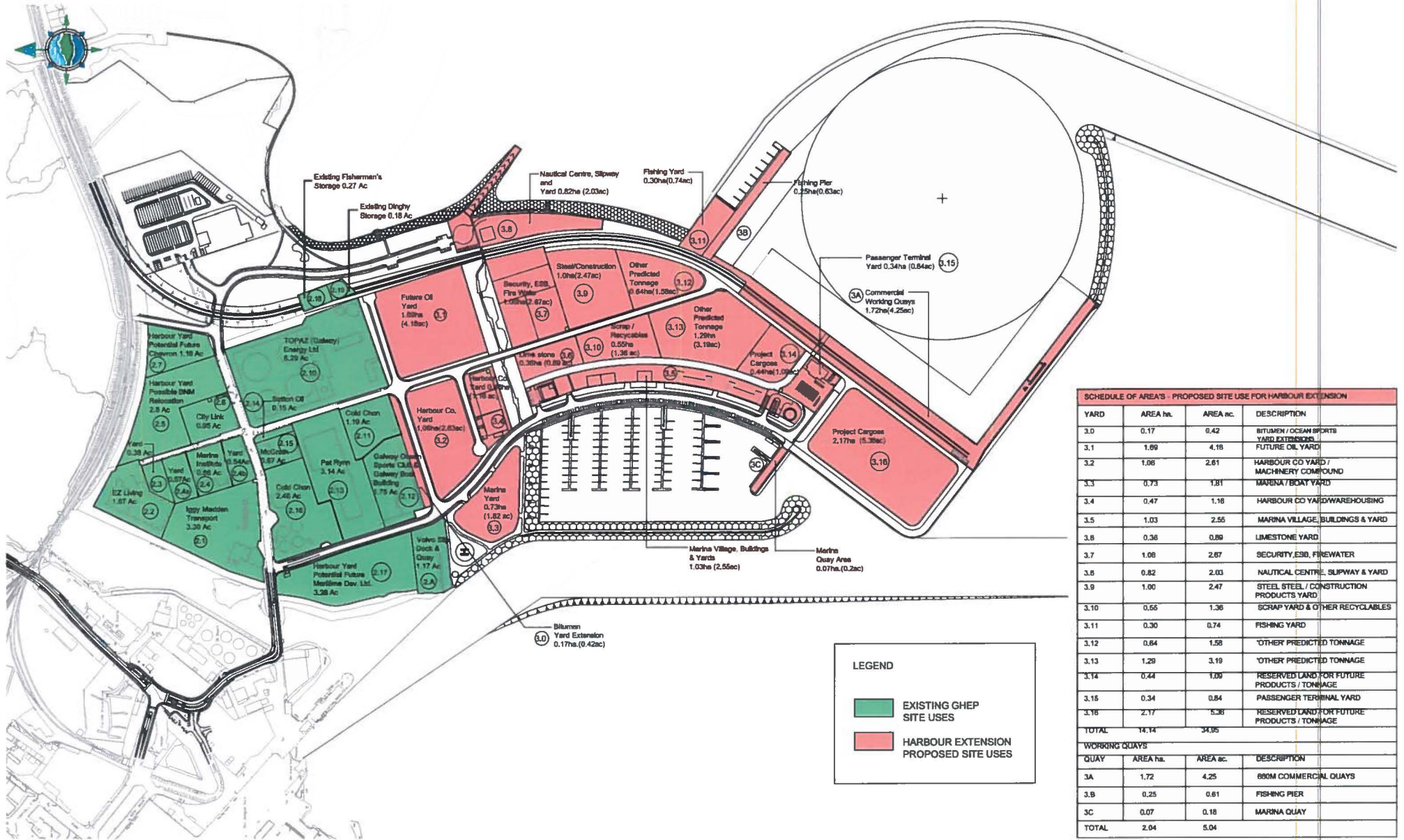

Galway Harbour Yards



PLATE 22 - STAGE 2 OF CONSTRUCTION

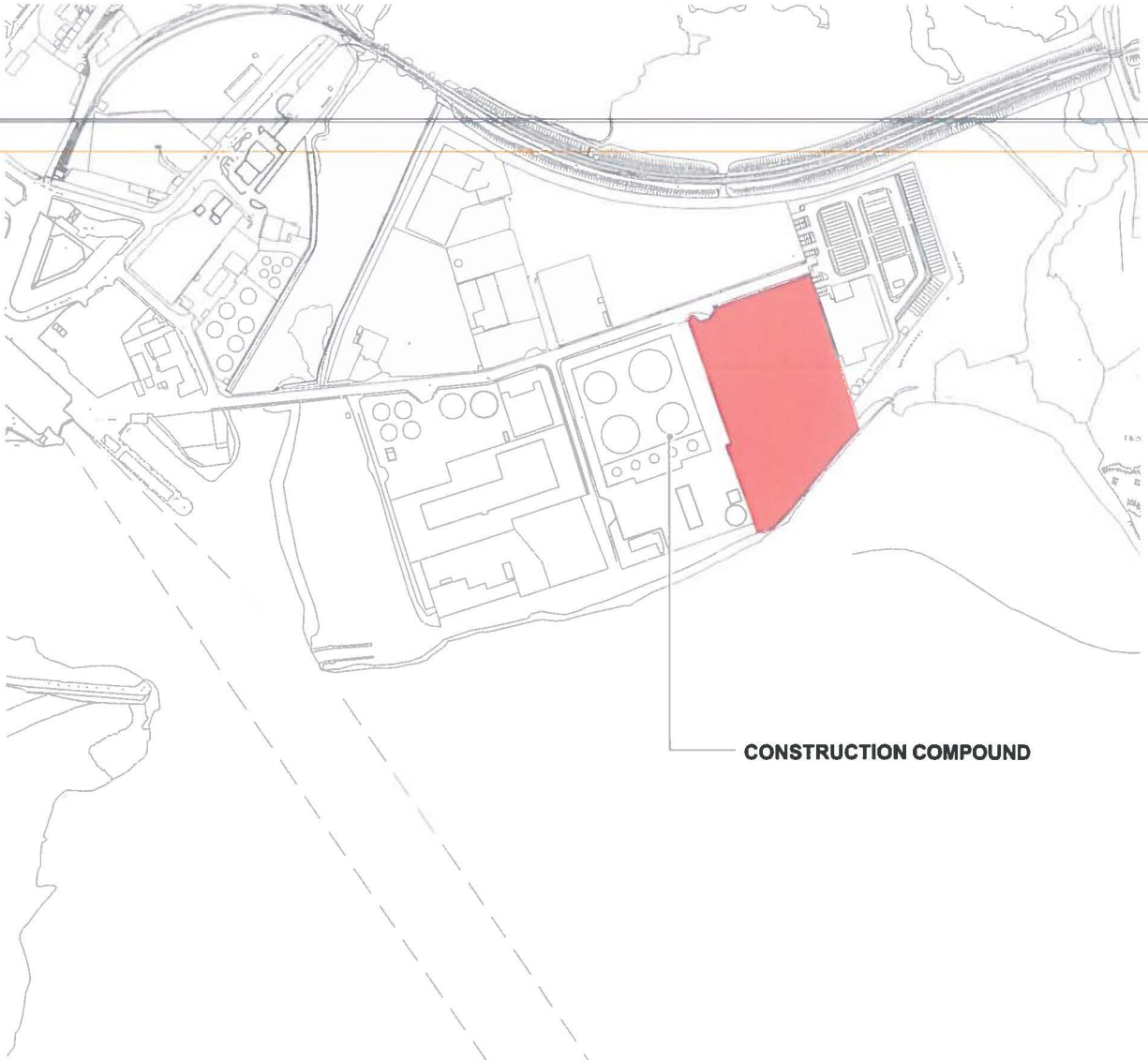

CONSTRUCTION COMPOUND

CONSTRUCTION COMPOUND

**1 CLEAR SITE TO FORM
CONSTRUCTION COMPOUND**



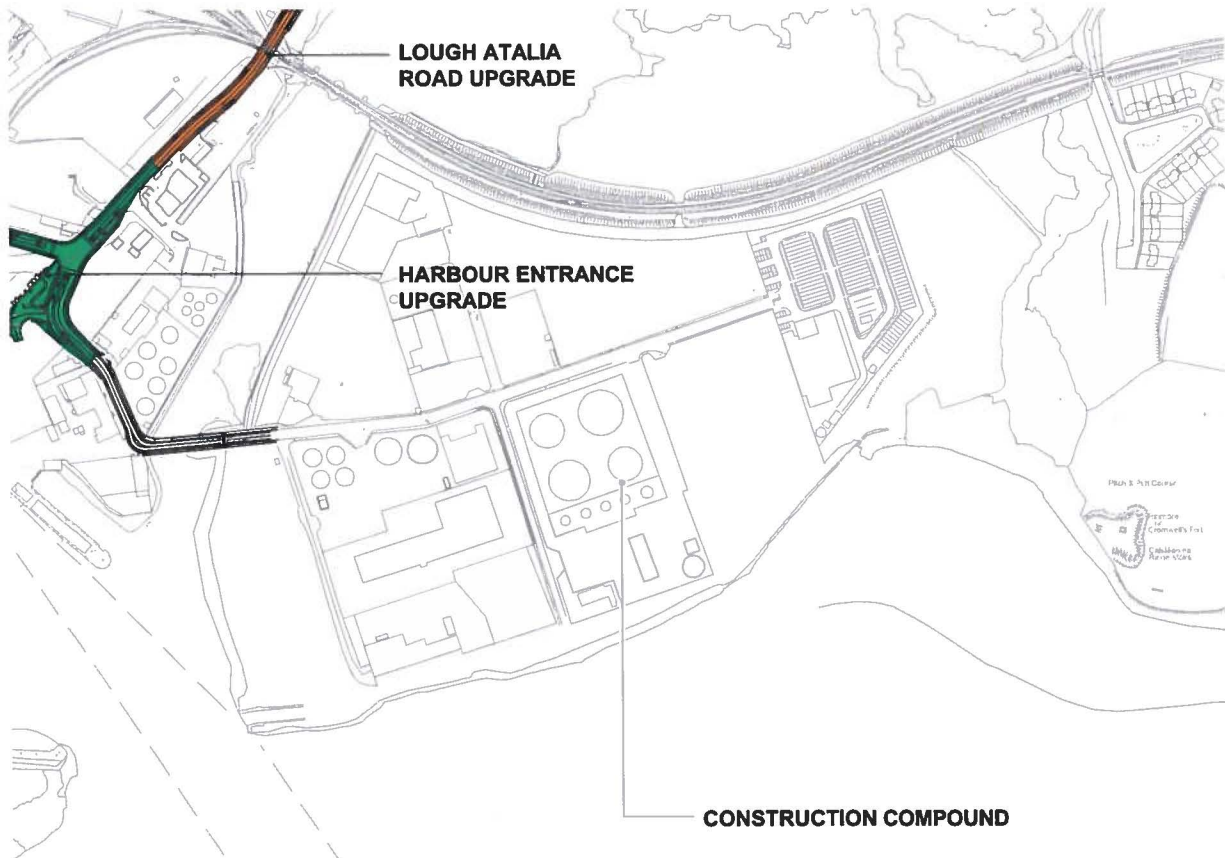

**LOUGH ATALIA ROAD UPGRADE,
HARBOUR ENTRANCE UPGRADE**

- 2.1 LOUGH ATALIA ROAD UPGRADE 
- 2.2 HARBOUR ENTRANCE UPGRADE 

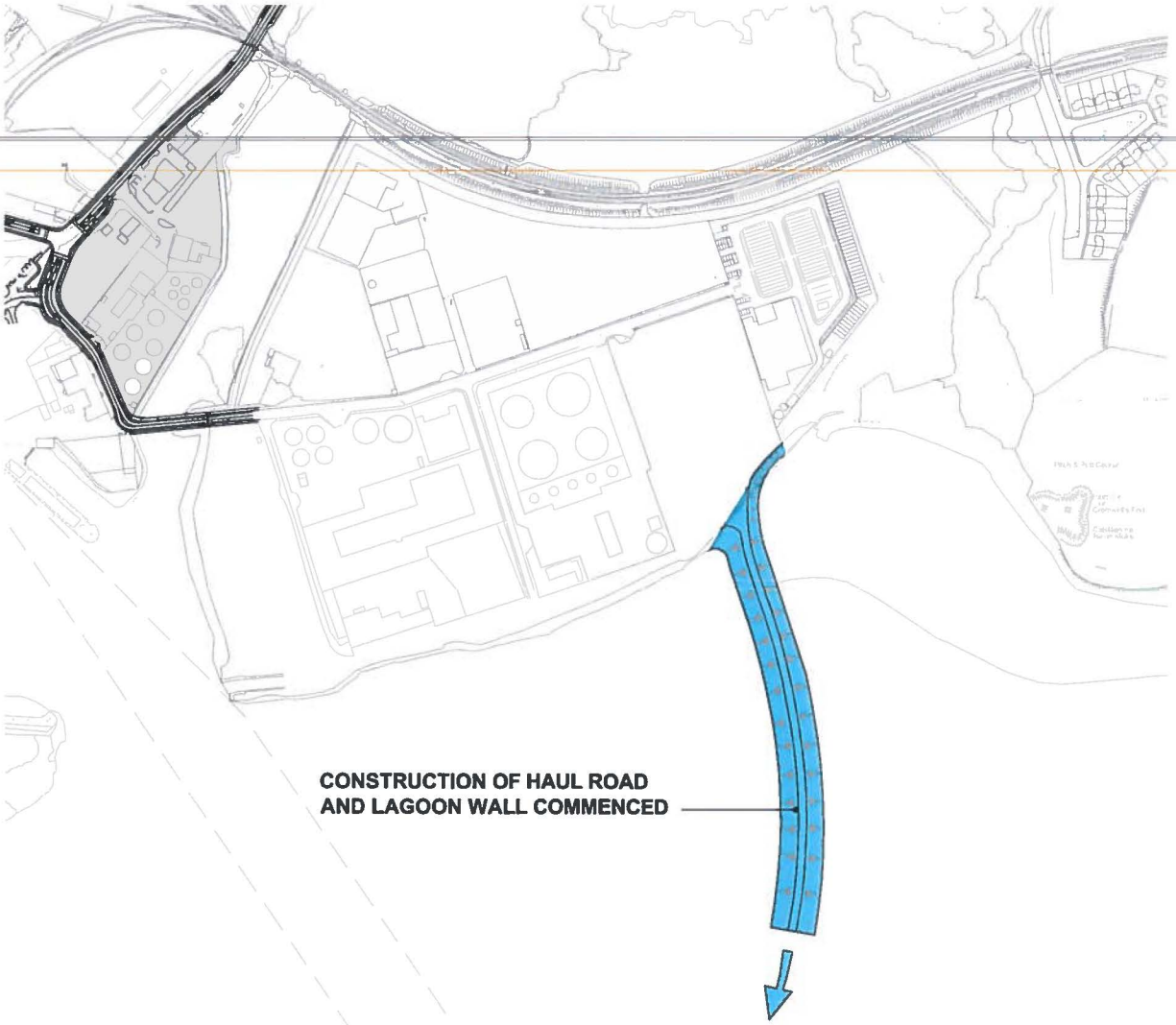

**CONSTRUCTION OF HAUL ROAD
AND LAGOON WALL COMMENCED**

**CONTINUED USE OF
EXISTING SHIPPING CHANNEL**

HAUL ROAD

- 3 COMMENCE CONSTRUCTION
OF HAUL ROAD**



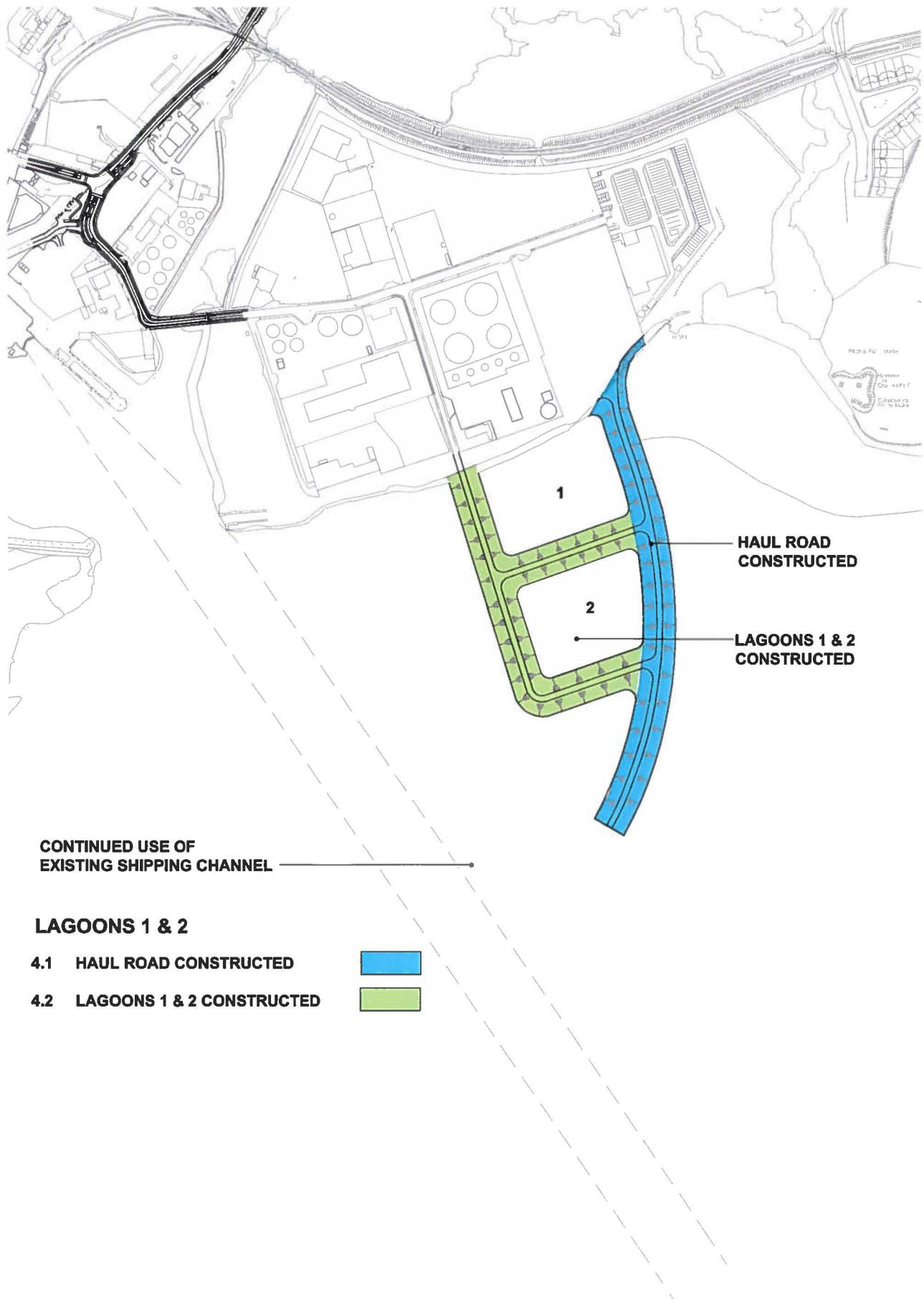

CONTINUED USE OF EXISTING SHIPPING CHANNEL

LAGOONS 1 & 2

4.1 HAUL ROAD CONSTRUCTED



4.2 LAGOONS 1 & 2 CONSTRUCTED



HAUL ROAD CONSTRUCTED

LAGOONS 1 & 2 CONSTRUCTED

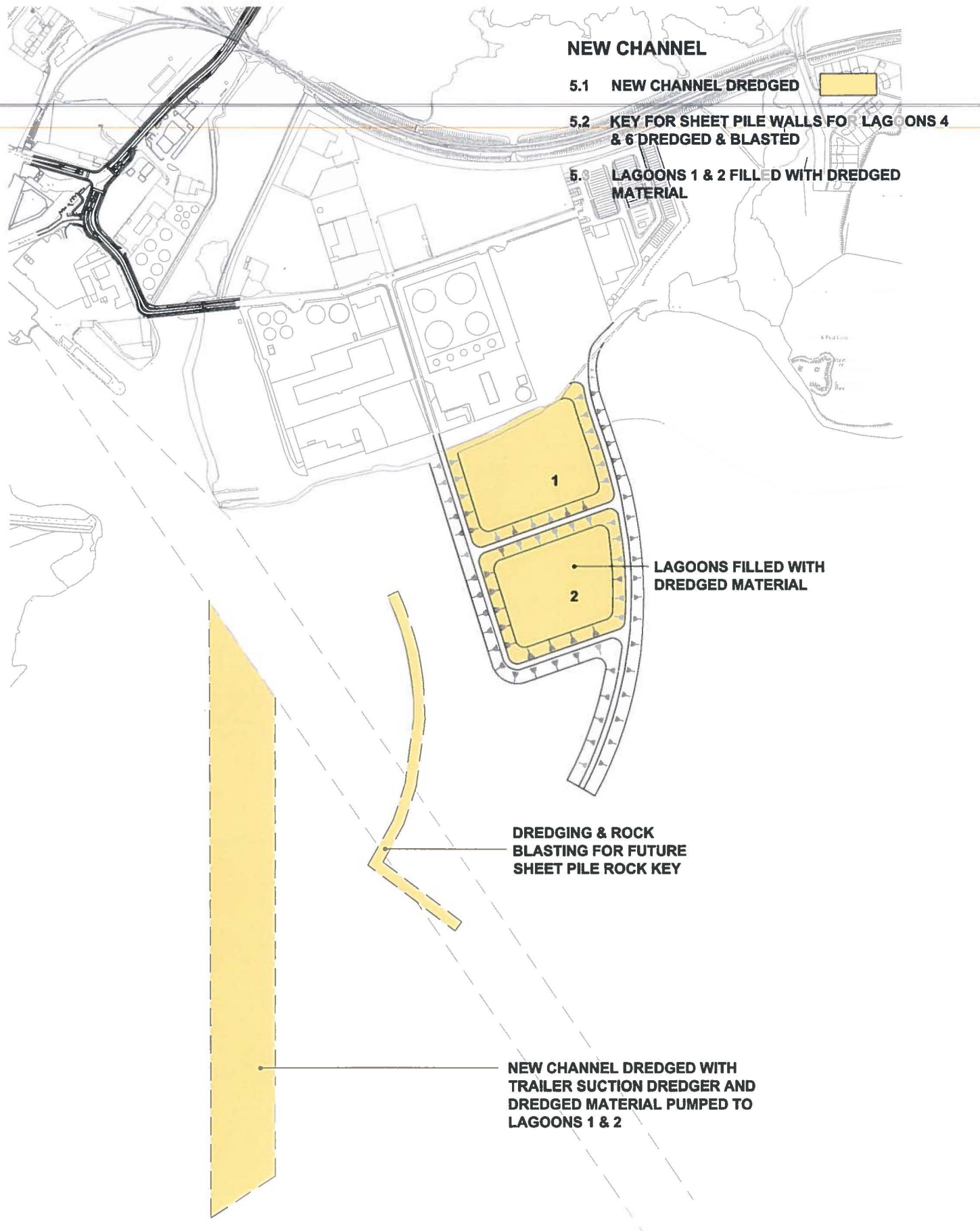

NEW CHANNEL

5.1 NEW CHANNEL DREDGED

5.2 KEY FOR SHEET PILE WALLS FOR LAGOONS 4 & 6 DREDGED & BLASTED

5.3 LAGOONS 1 & 2 FILLED WITH DREDGED MATERIAL

LAGOONS FILLED WITH DREDGED MATERIAL

DREDGING & ROCK BLASTING FOR FUTURE SHEET PILE ROCK KEY

NEW CHANNEL DREDGED WITH TRAILER SUCTION DREDGER AND DREDGED MATERIAL PUMPED TO LAGOONS 1 & 2

Construction Element No. 5

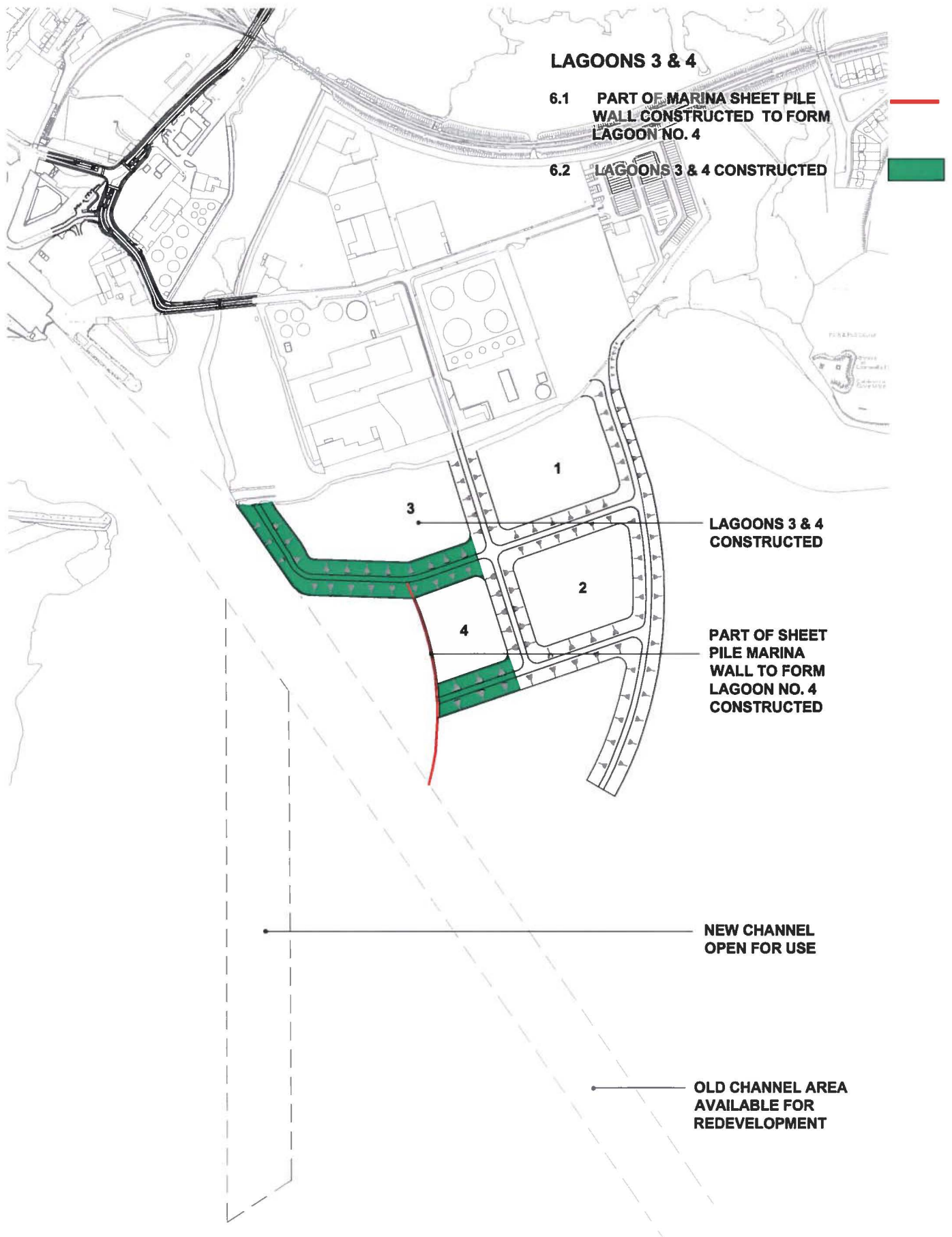

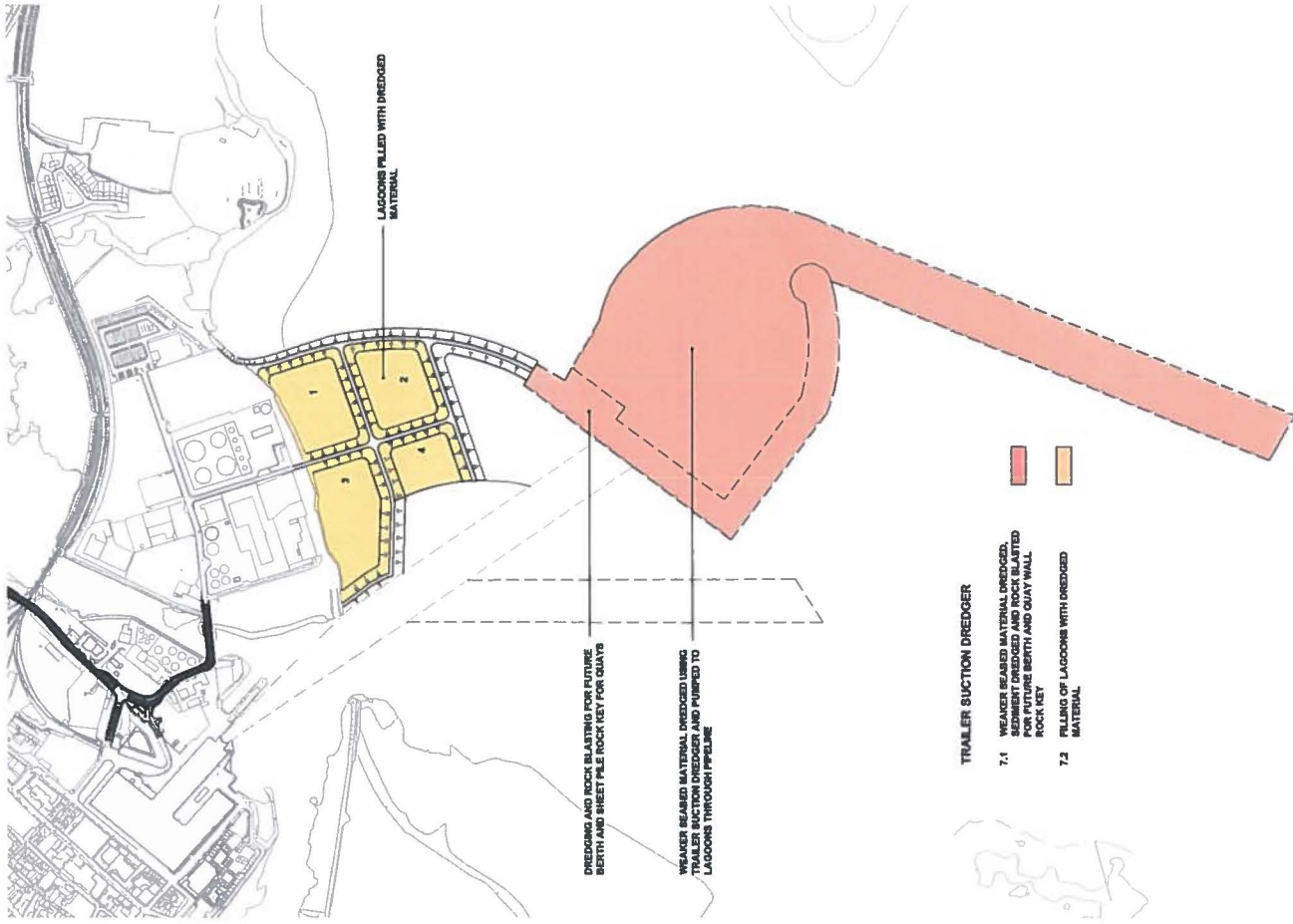

Construction Element No. 7

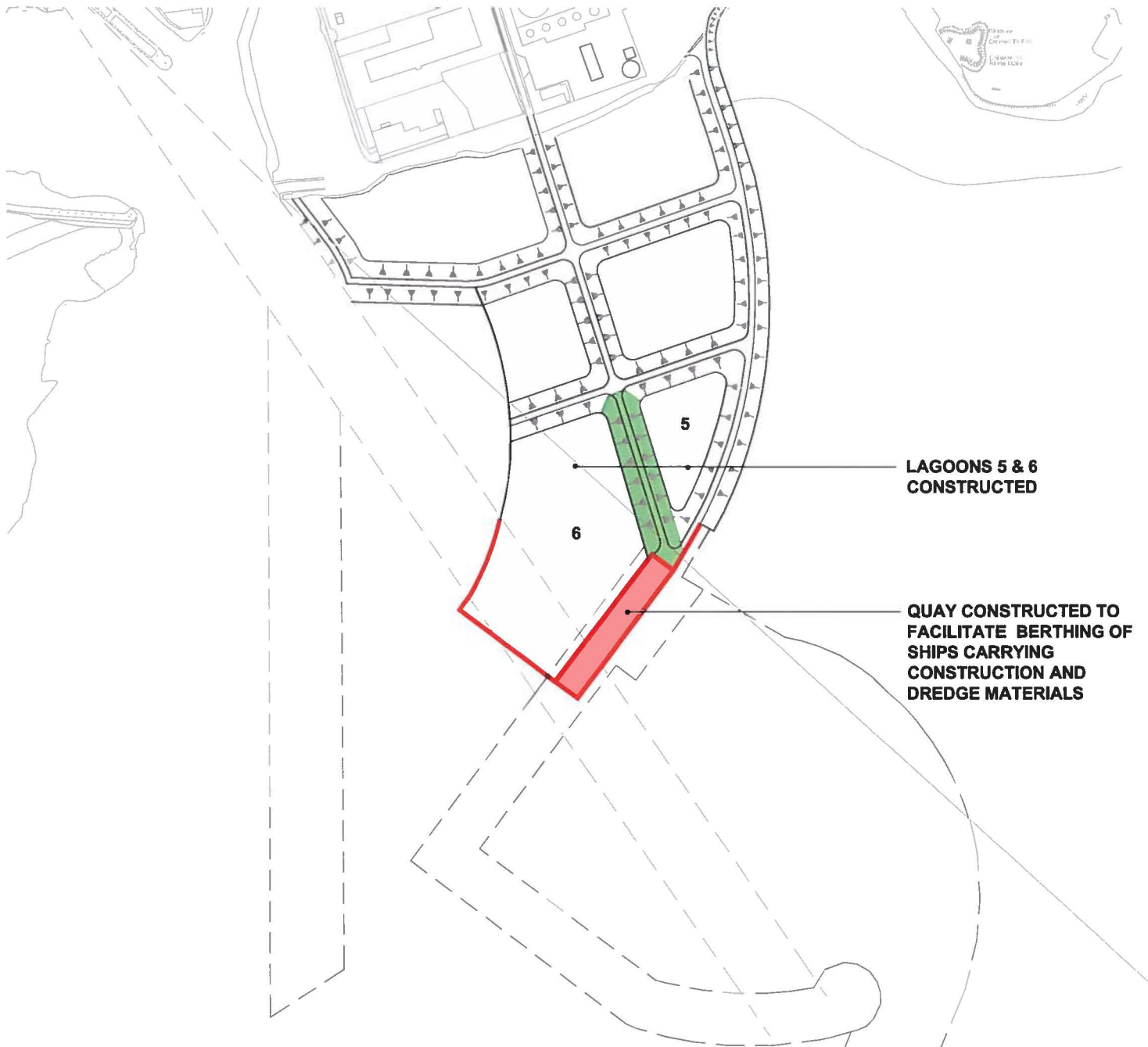

**LAGOONS 5 & 6
CONSTRUCTED**

**QUAY CONSTRUCTED TO
FACILITATE BERTHING OF
SHIPS CARRYING
CONSTRUCTION AND
DREDGE MATERIALS**

CONSTRUCTION QUAY

- 8.1 LAGOONS 5 & 6 CONSTRUCTED
 - 8.2 QUAY CONSTRUCTED TO ALLOW FOR BERTHAGE OF SHIPS CARRYING CONSTRUCTION AND DREDGE MATERIAL
- SHEET PILE





MAIN DREDGE

- 9 BERTHS, TURNING CIRCLE AND ACCESS CHANNEL DREDGED
- PLACEMENT OF DREDGED MATERIAL IN LAGOONS 1 - 6

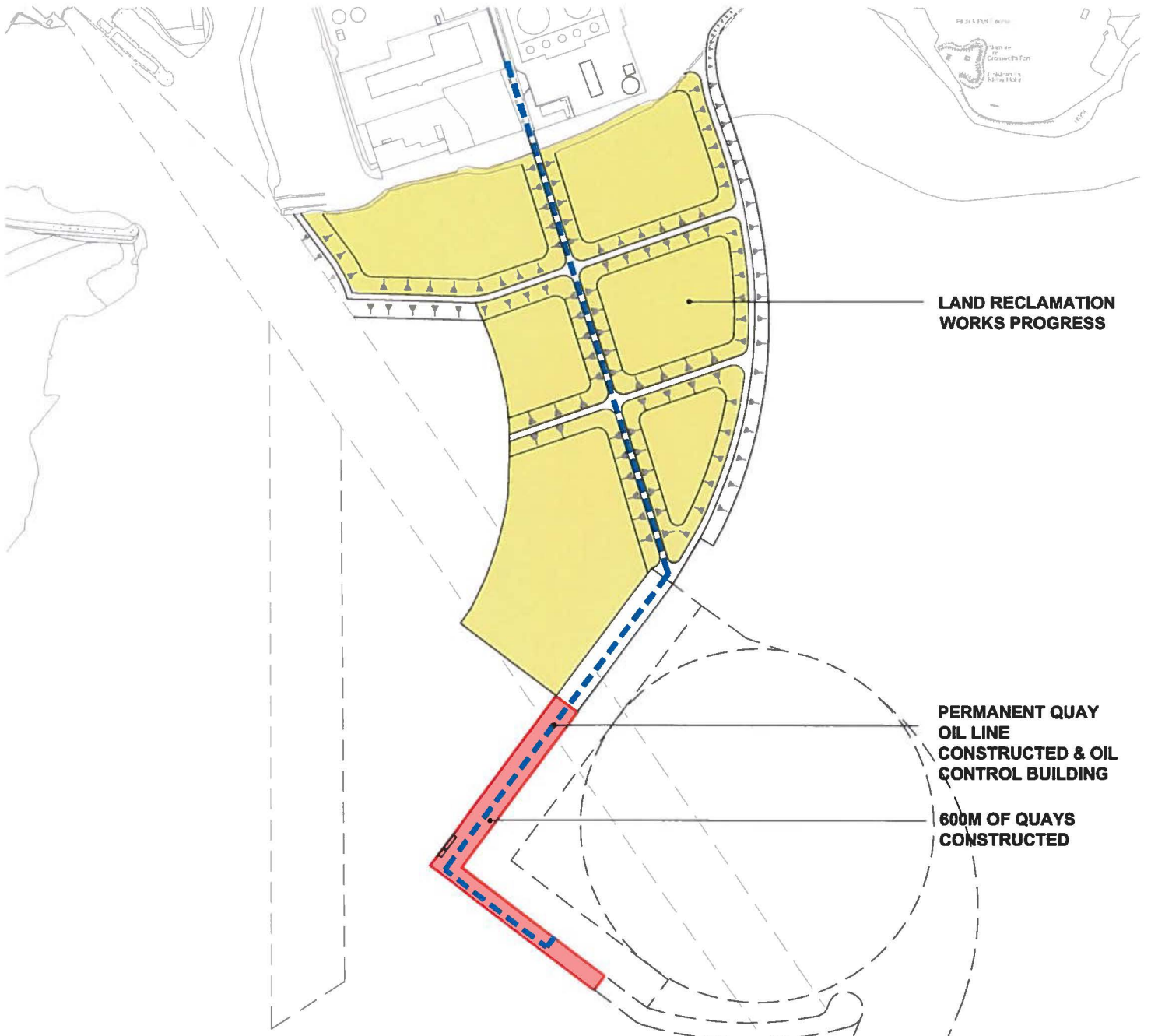

**LAND RECLAMATION
WORKS PROGRESS**

**PERMANENT QUAY
OIL LINE
CONSTRUCTED & OIL
CONTROL BUILDING**

**600M OF QUAYS
CONSTRUCTED**

**600m OF NEW QUAYS
COMMERCIAL & PASSENGER PORT ACCESSIBLE
OVER EASTERLY HAUL ROAD**

- 10.1 600M OF QUAYS CONSTRUCTED
- 10.2 LAND RECLAMATION WORKS PROGRESS
- 10.3 PERMANENT QUAY OIL LINES CONSTRUCTED



PLATE 21 - STAGE 1 OF CONSTRUCTION



60M OF QUAY WALL
CONSTRUCTED

260M OF BREAKWATER CONSTRUCTED

PIER & BREAKWATER ROCK DREDGE

COMMERCIAL & PASSENGER PORT COMPLETED

11.1 ROCK DREDGE FOR 60M OF QUAY
WALL & 260M OF BREAKWATER



11.2 60M OF QUAY & 260M OF BREAKWATER
CONSTRUCTED





LAND RECLAMATION WORKS IN PROGRESS

SHEET PILE WALL TO FORM LAGOON NO. 7

LAGOON NO.7 , SHEET PILE WALLS

- 12.1 DREDGE KEY FOR LAGOON WALL 7
- 12.2 SHEET PILE WALL CONSTRUCTED TO FORM LAGOON NO. 7
- 12.3 RAIL LINE EMBANKMENTS AND ROAD UNDERPASS TO CIE CONSTRUCTED
- 12.4 LAND RECLAMATION WORKS IN PROGRESS



PLATE 22 - STAGE 2 OF CONSTRUCTION

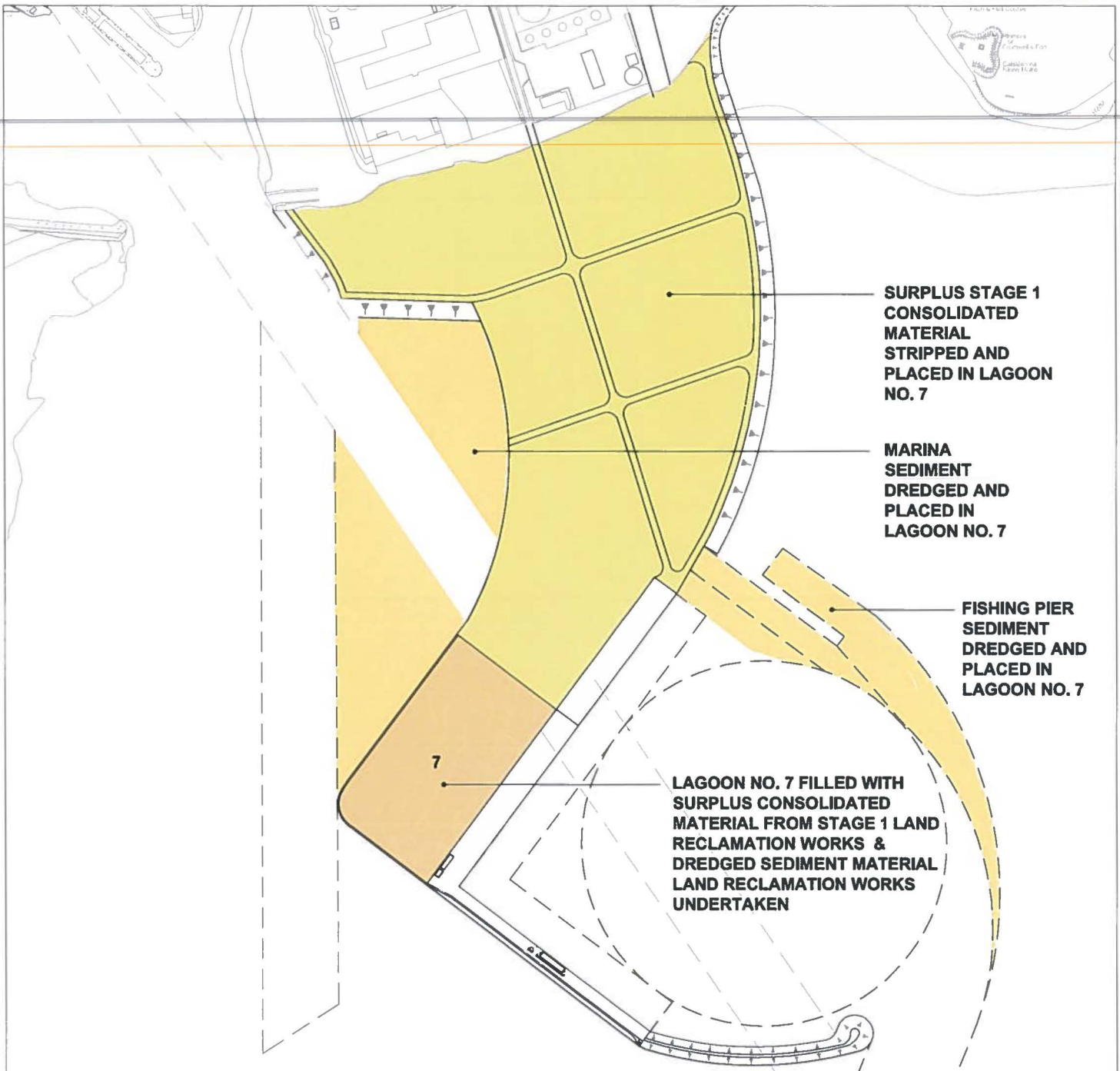

SURPLUS STAGE 1 CONSOLIDATED MATERIAL STRIPPED AND PLACED IN LAGOON NO. 7

MARINA SEDIMENT DREDGED AND PLACED IN LAGOON NO. 7

FISHING PIER SEDIMENT DREDGED AND PLACED IN LAGOON NO. 7

LAGOON NO. 7 FILLED WITH SURPLUS CONSOLIDATED MATERIAL FROM STAGE 1 LAND RECLAMATION WORKS & DREDGED SEDIMENT MATERIAL LAND RECLAMATION WORKS UNDERTAKEN

COMPLETE DREDGE AND FILL

- 13.1 SURPLUS STAGE 1 CONSOLIDATED MATERIAL STRIPPED AND PLACED IN LAGOON NO. 7
- 13.2 SEDIMENT DREDGED AND PLACED IN LAGOON NO. 7
- 13.3 LAGOON NO. 7 FILLED WITH SURPLUS STAGE 1 CONSOLIDATED MATERIAL AND DREDGED SEDIMENT MATERIAL

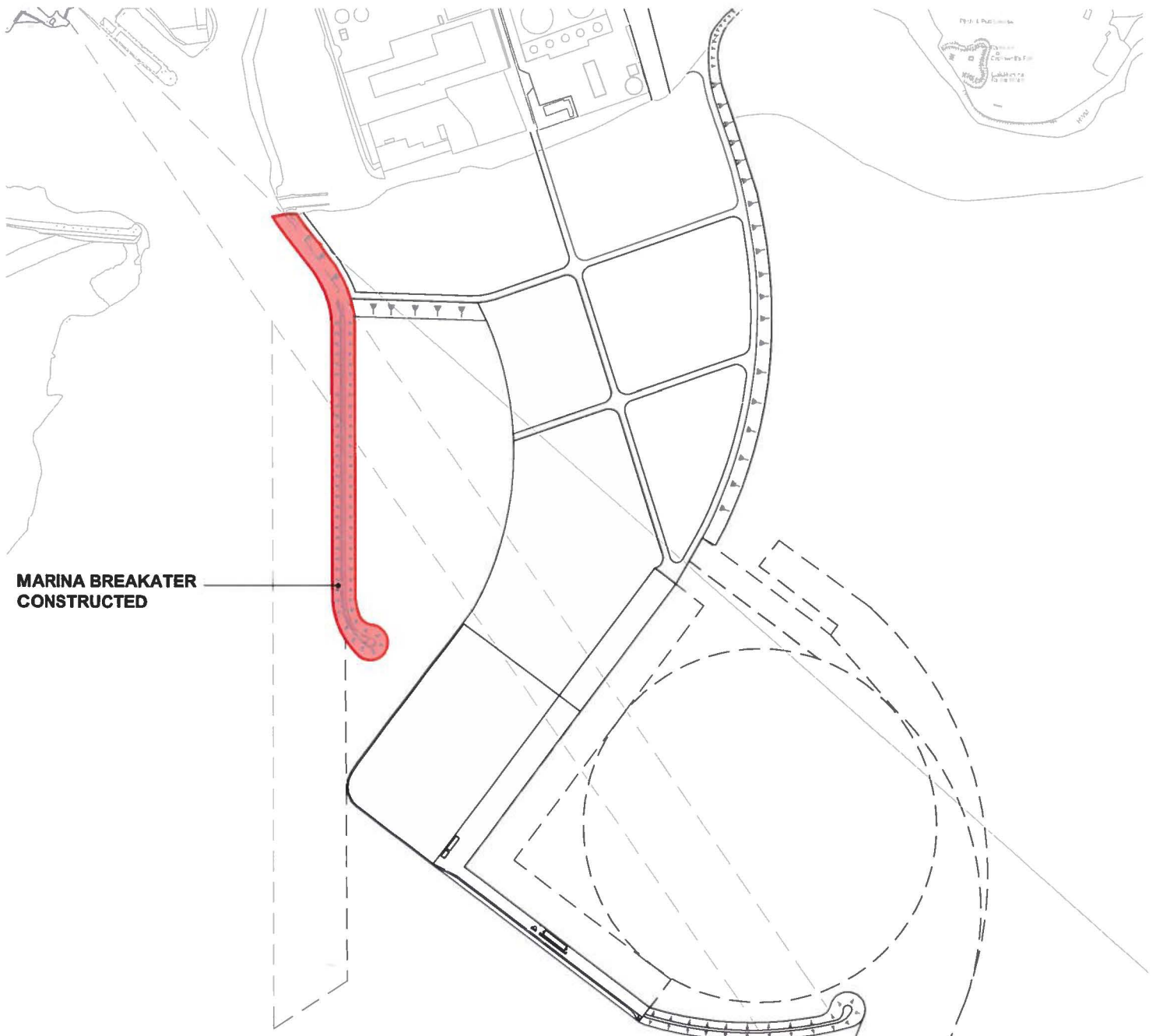

**MARINA BREAKATER
CONSTRUCTED**

MARINA BREAKWATER

14.1 MARINA BREAKWATER WALL ROCK DREDGED

14.2 MARINA BREAKWATER CONSTRUCTED



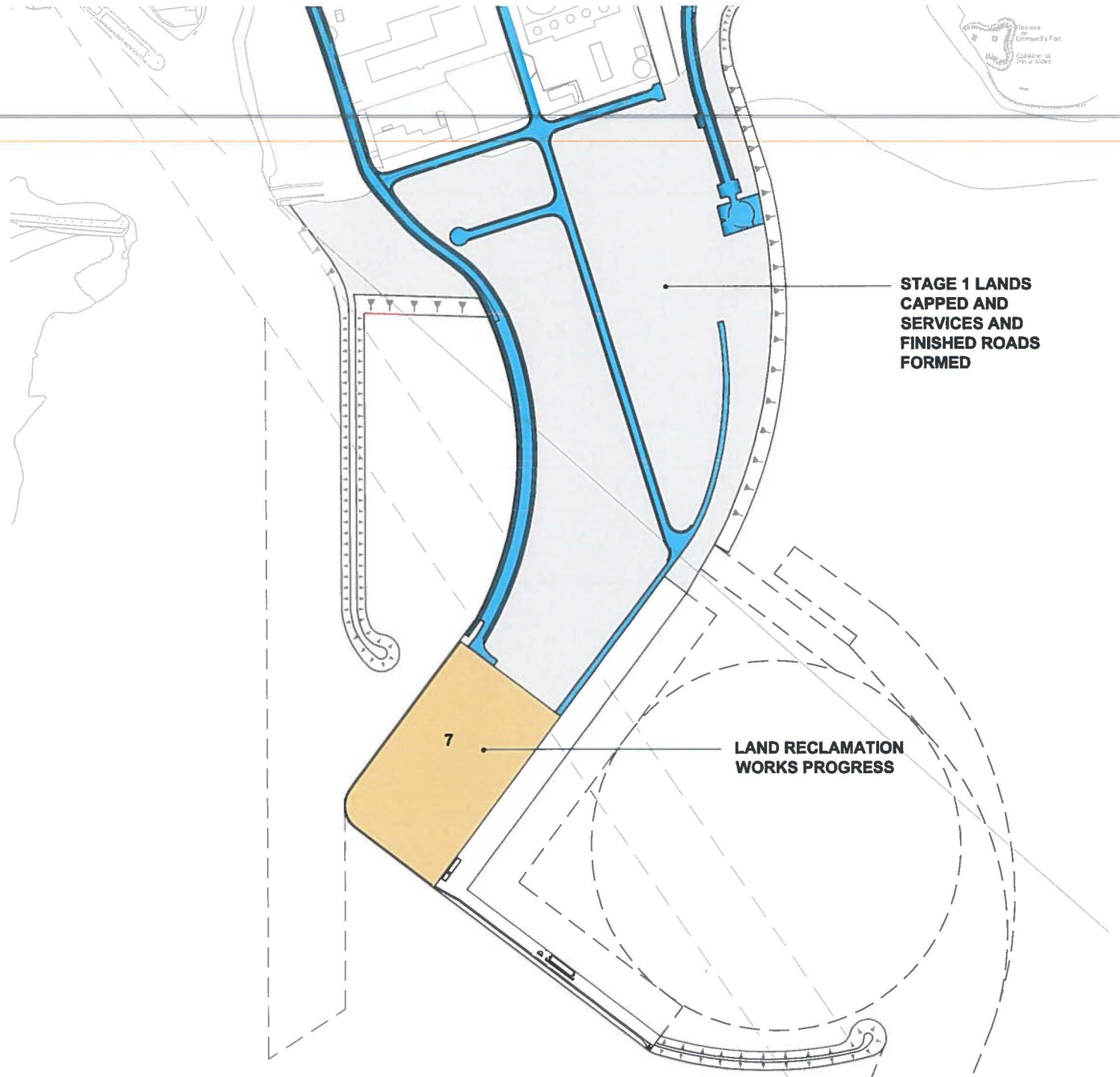

STAGE 1 LANDS CAPPED AND SERVICES AND FINISHED ROADS FORMED

LAND RECLAMATION WORKS PROGRESS

CAP YARDS (LAGOONS 1 - 6)

- 15.1 STAGE 1 LANDS CAPPED INCLUDING PROVISION OF SERVICES
- 15.2 FINISHED ROADS AND SERVICES CONSTRUCTED
- 15.3 LAND RECLAMATION WORKS PROGRESS

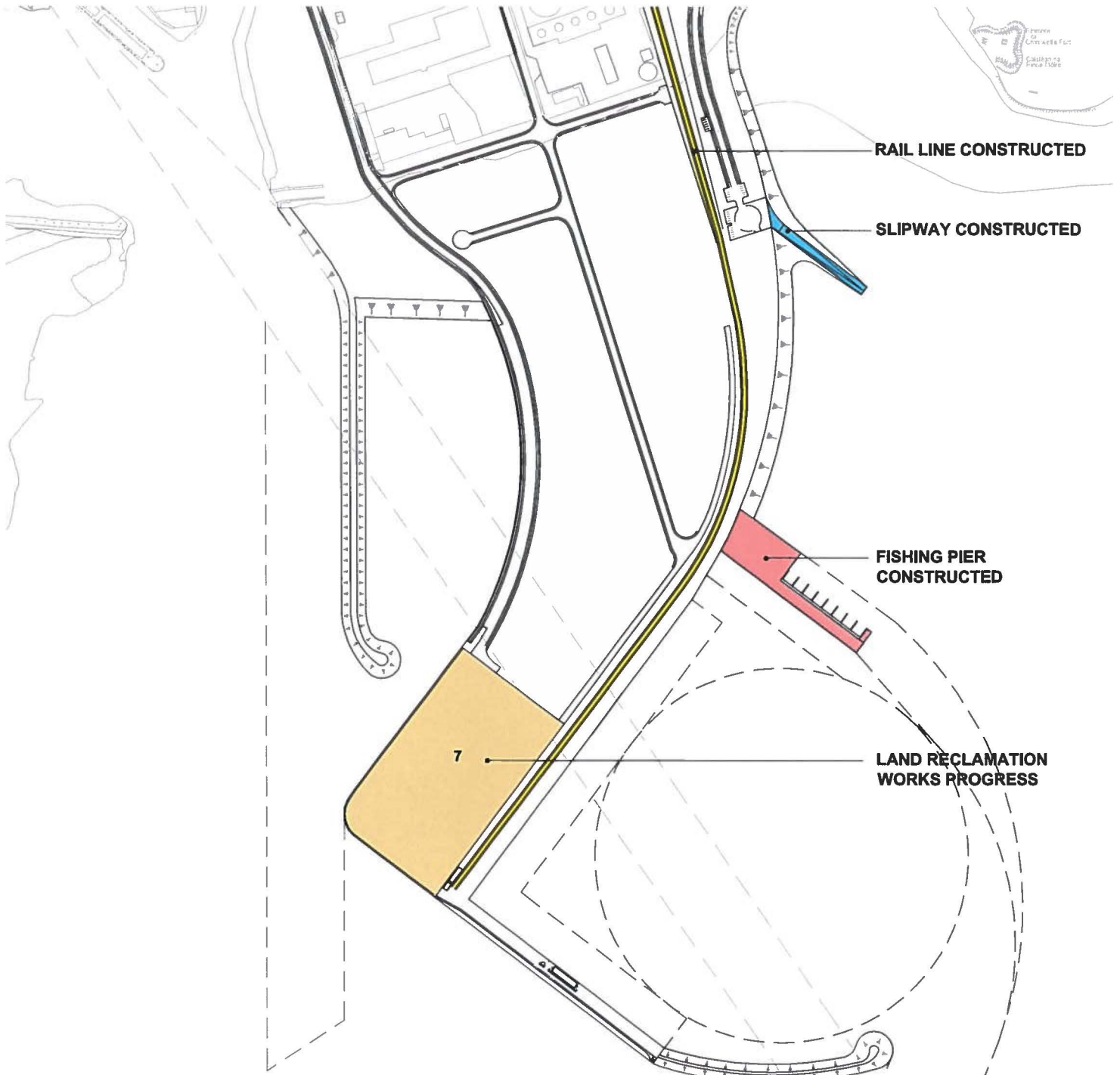

RAIL LINE CONSTRUCTED

SLIPWAY CONSTRUCTED

FISHING PIER CONSTRUCTED

LAND RECLAMATION WORKS PROGRESS

7

RAIL, SLIPWAY, FISHING PIER

- 16.1 RAIL LINE CONSTRUCTED
- 16.2 SLIPWAY CONSTRUCTED
- 16.3 FISHING PIER CONSTRUCTED
- 16.4 LAND RECLAMATION WORKS PROGRESS

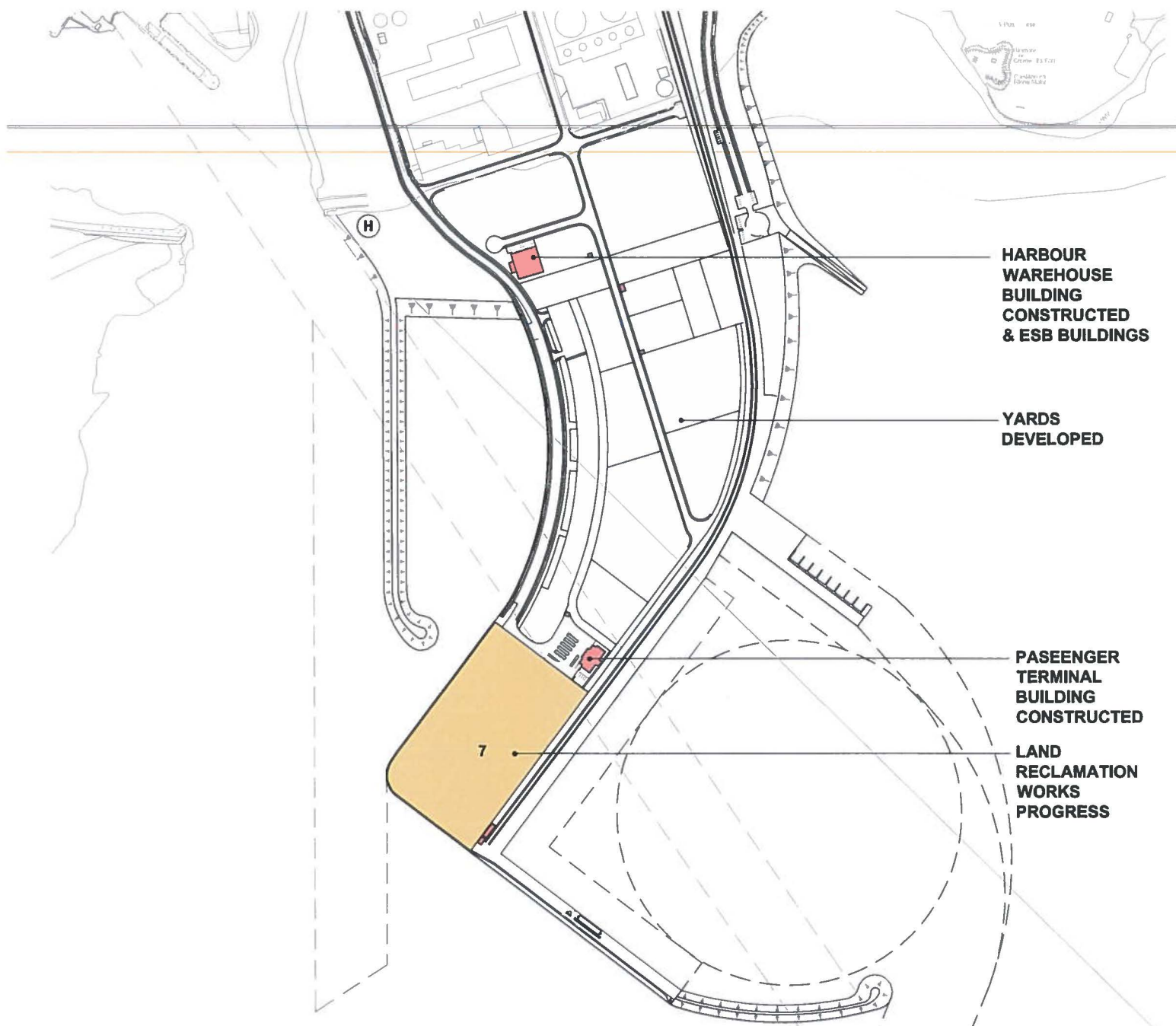

**HARBOUR
WAREHOUSE
BUILDING
CONSTRUCTED
& ESB BUILDINGS**

**YARDS
DEVELOPED**

**PASSENGER
TERMINAL
BUILDING
CONSTRUCTED**

**LAND
RECLAMATION
WORKS
PROGRESS**

SERVICE YARDS, ERECT BUILDINGS

- 17.1 BUILDINGS CONSTRUCTED
- 17.2 YARDS DEVELOPED
- 17.3 LAND RECLAMATION WORKS PROGRESS

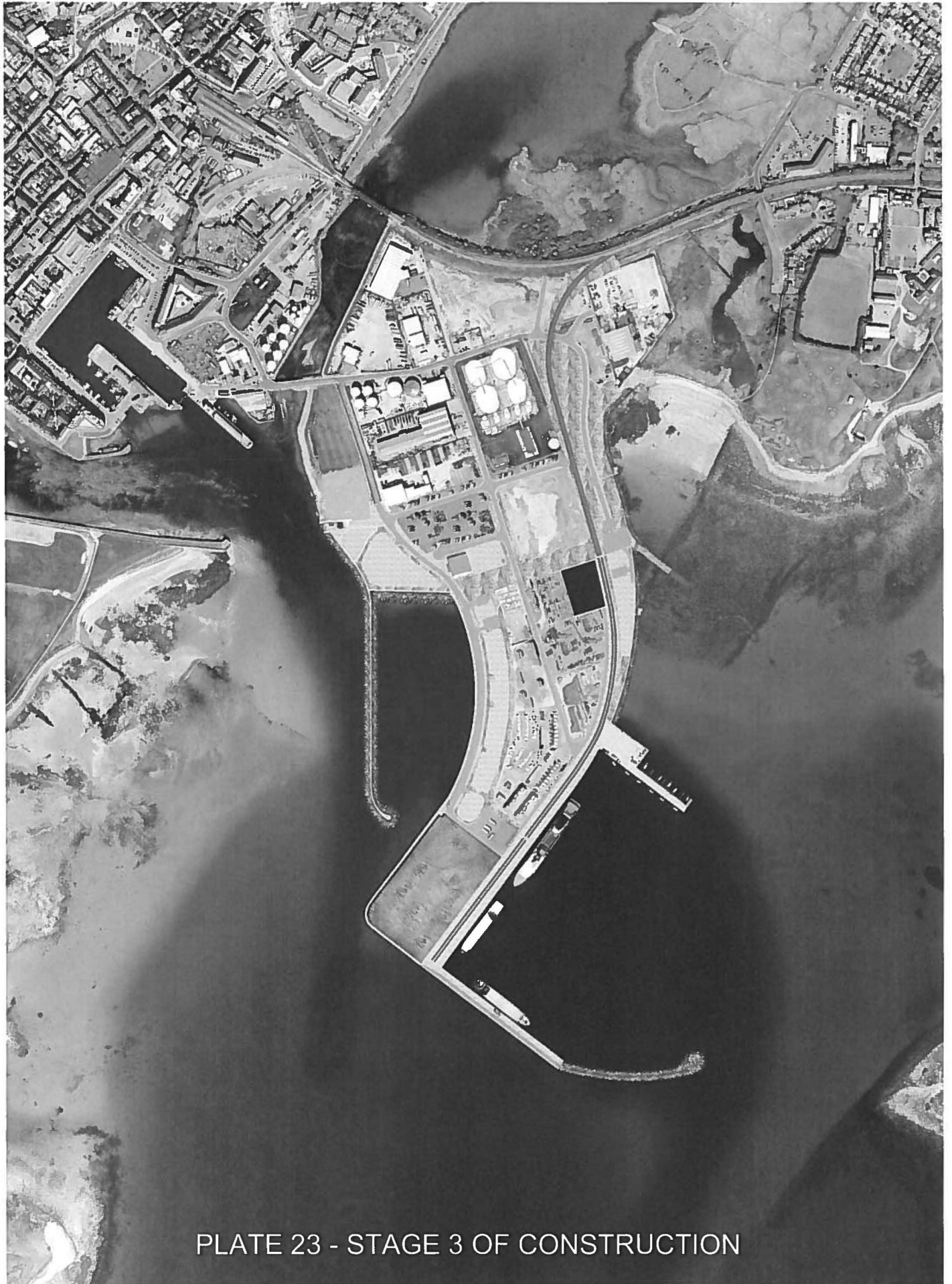
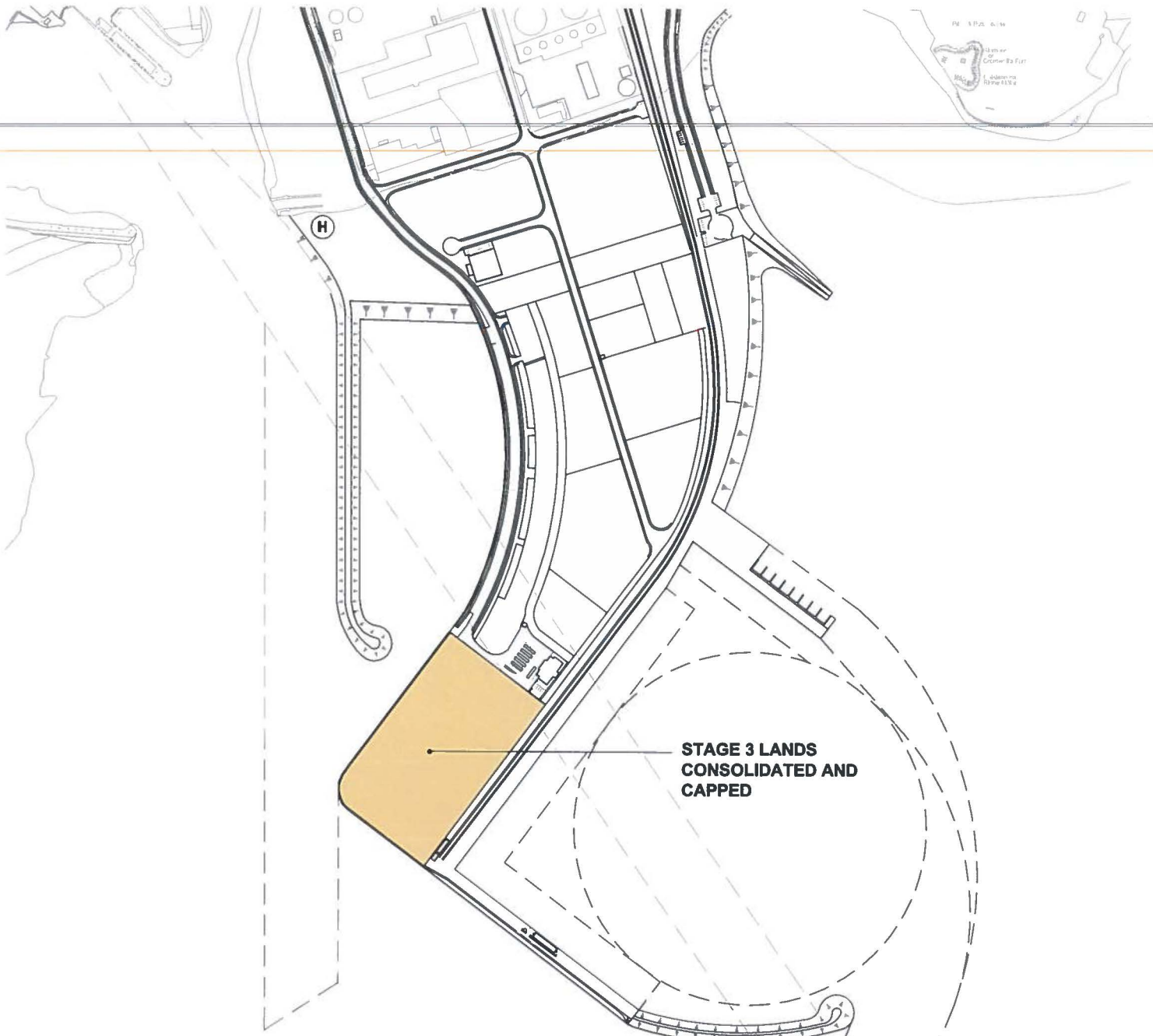

PLATE 23 - STAGE 3 OF CONSTRUCTION



CAP YARDS (LAGOON NO. 7)

18 STAGE 3 LANDS CONSOLIDATED AND CAPPED



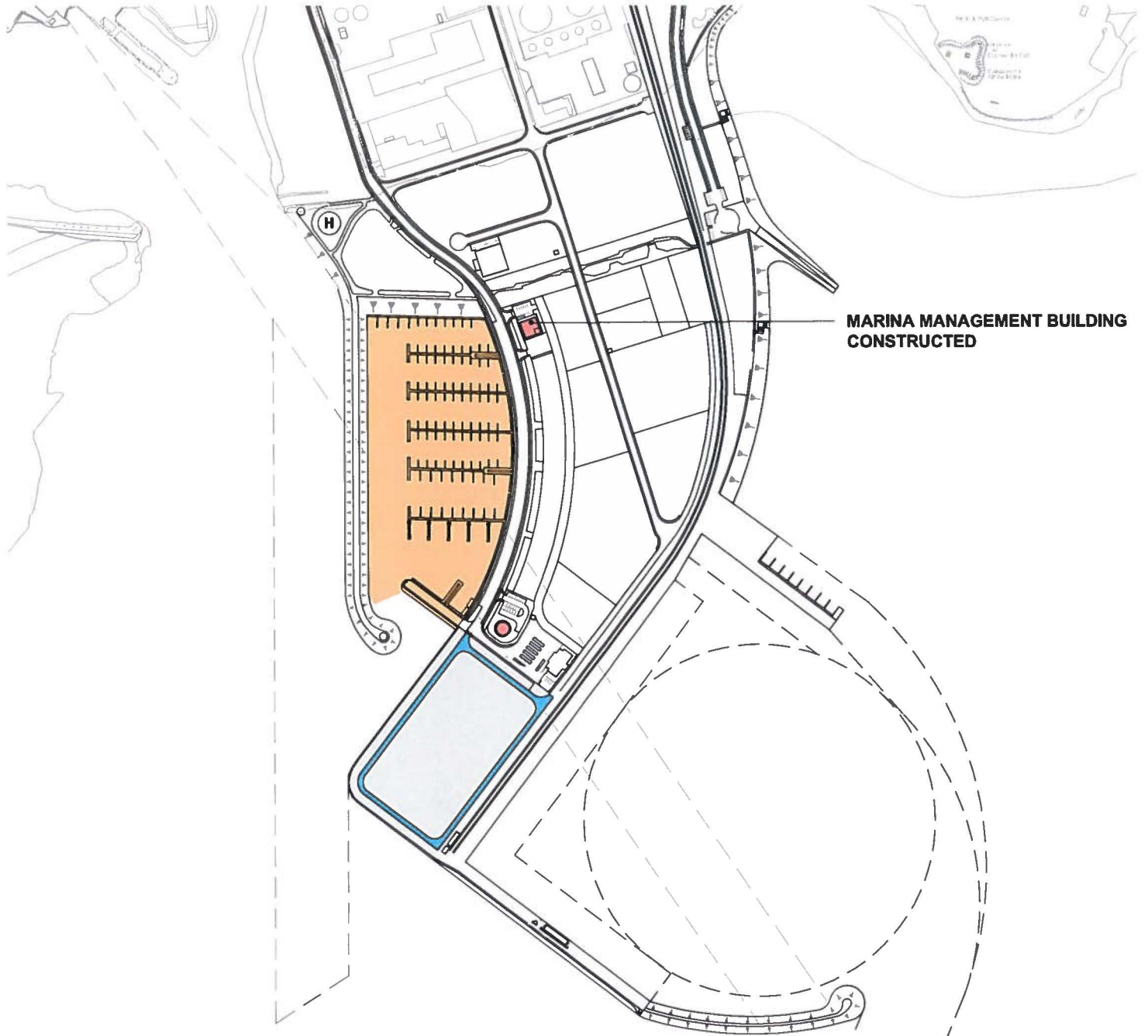

**MARINA MANAGEMENT BUILDING
CONSTRUCTED**

MARINA FIT OUT, SERVICE YARDS, CONSTRUCT BUILDINGS



PLATE 24 - STAGE 4 OF CONSTRUCTION

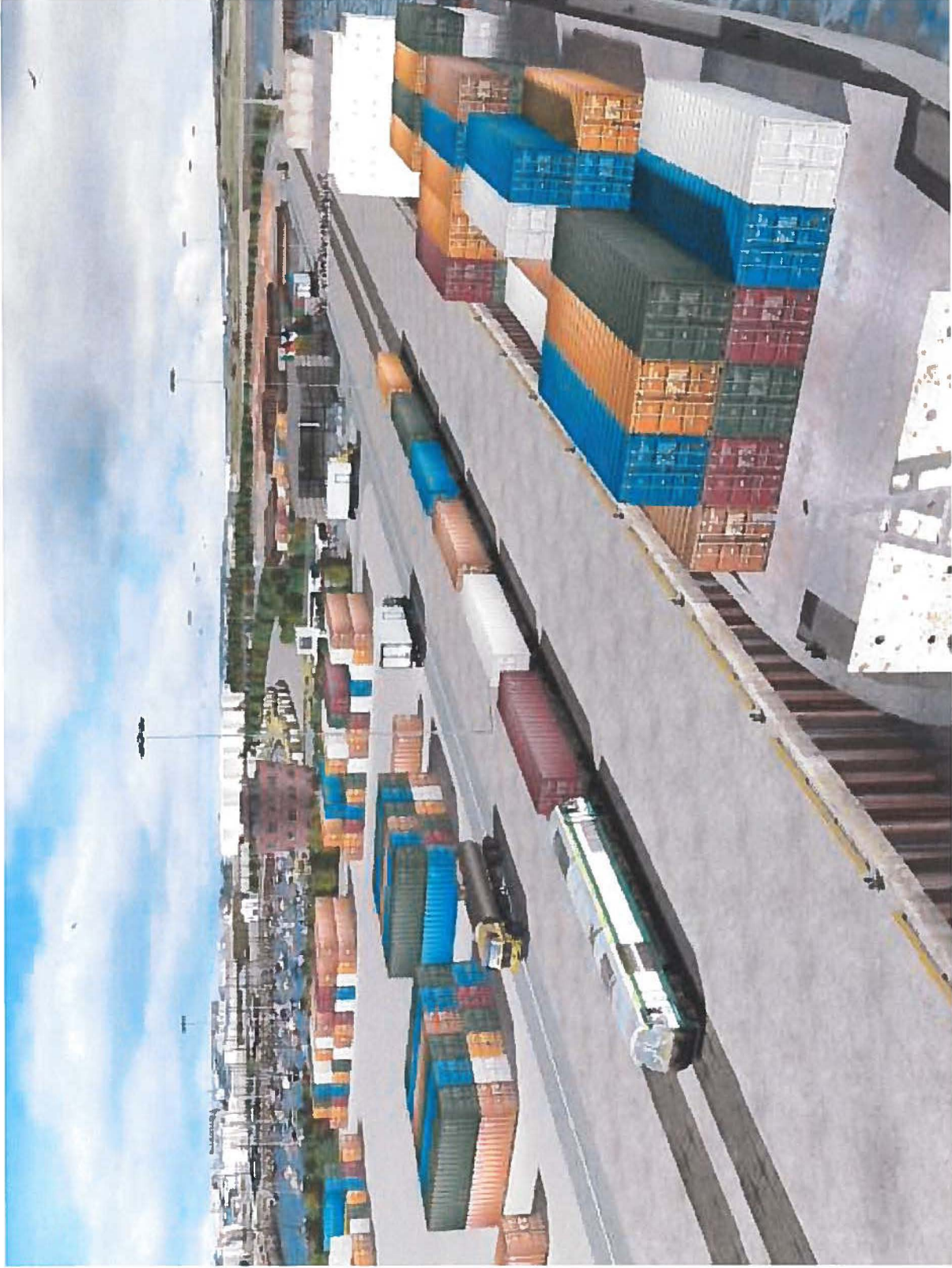

COMPLETED



COMPLETED



COMPLETED

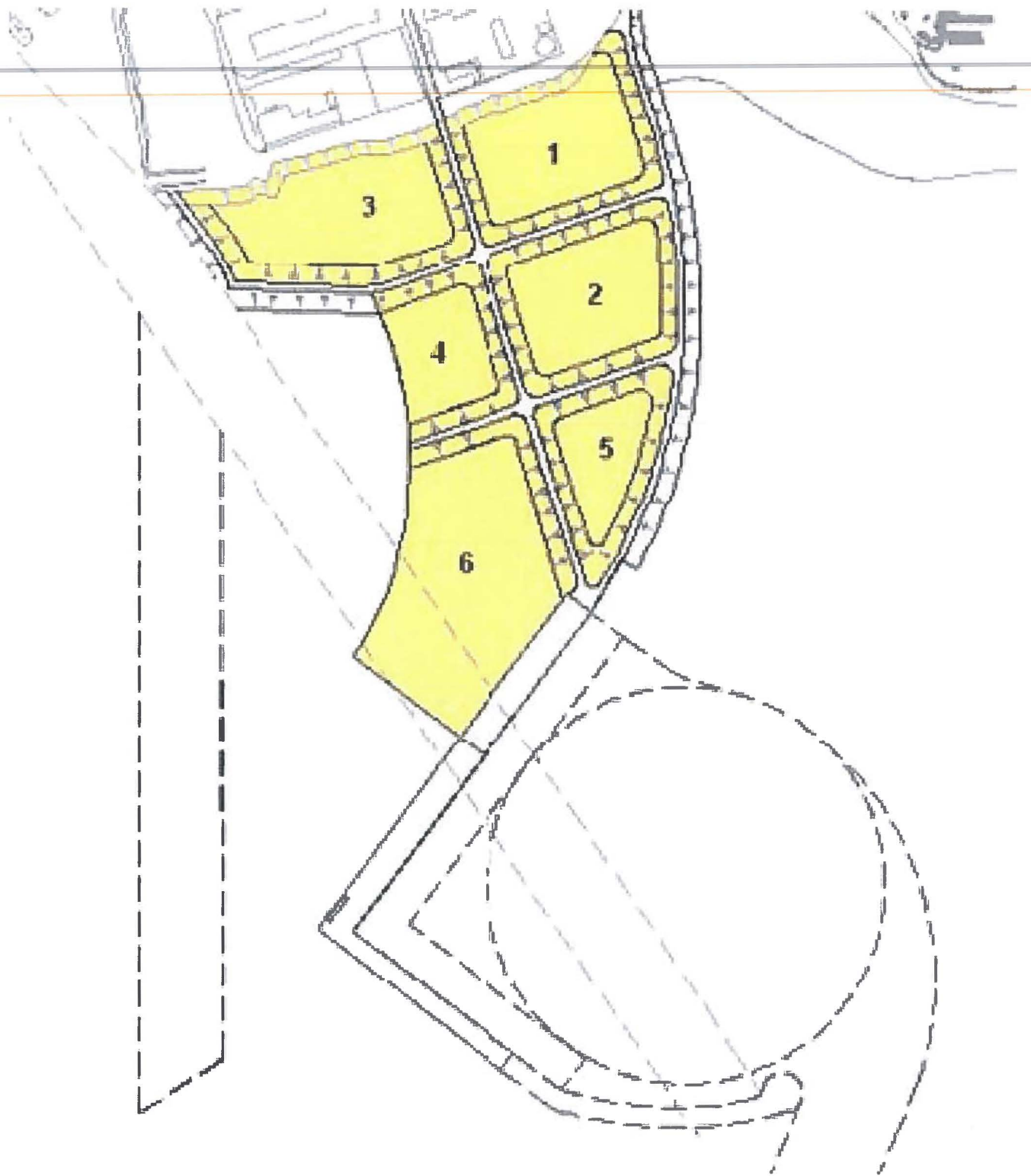

Lagoon Wall Construction

LAGOON / YARDAGE

Proposed Surcharge Level 6.7m OD (9.0m CD)

Proposed Ground Level 4.7m OD (7.0m CD)

Anchored Precast Safety Kerb Beam - 0.5m x 0.5m x 6m 1.0

Bund formed with crushed rock typically 150/50 mm sizing

Existing Sea Bed level -2.9m OD (0.0m CD)

-1.9m OD (-1.0m CD)

Existing Bedrock Level -5.6m OD (-2.7m CD)

7.0m

Head of Rock Armour to provide sea side safety barrier for construction traffic during land reclamation

SEA

Head of Rock Armour brought to proposed ground level upon completion of land consolidation and boulder wall constructed

MIWS 2.2m OD (5.1m CD)

Rock Armour - 2 tonne (2 layers min.)

Secondary Layer - typically 300mm sizing

MLWS -2.3m OD (0.6m CD)

Existing Gravelly Sand with Cobbles

1.5
1.0

Lagoon Wall Construction

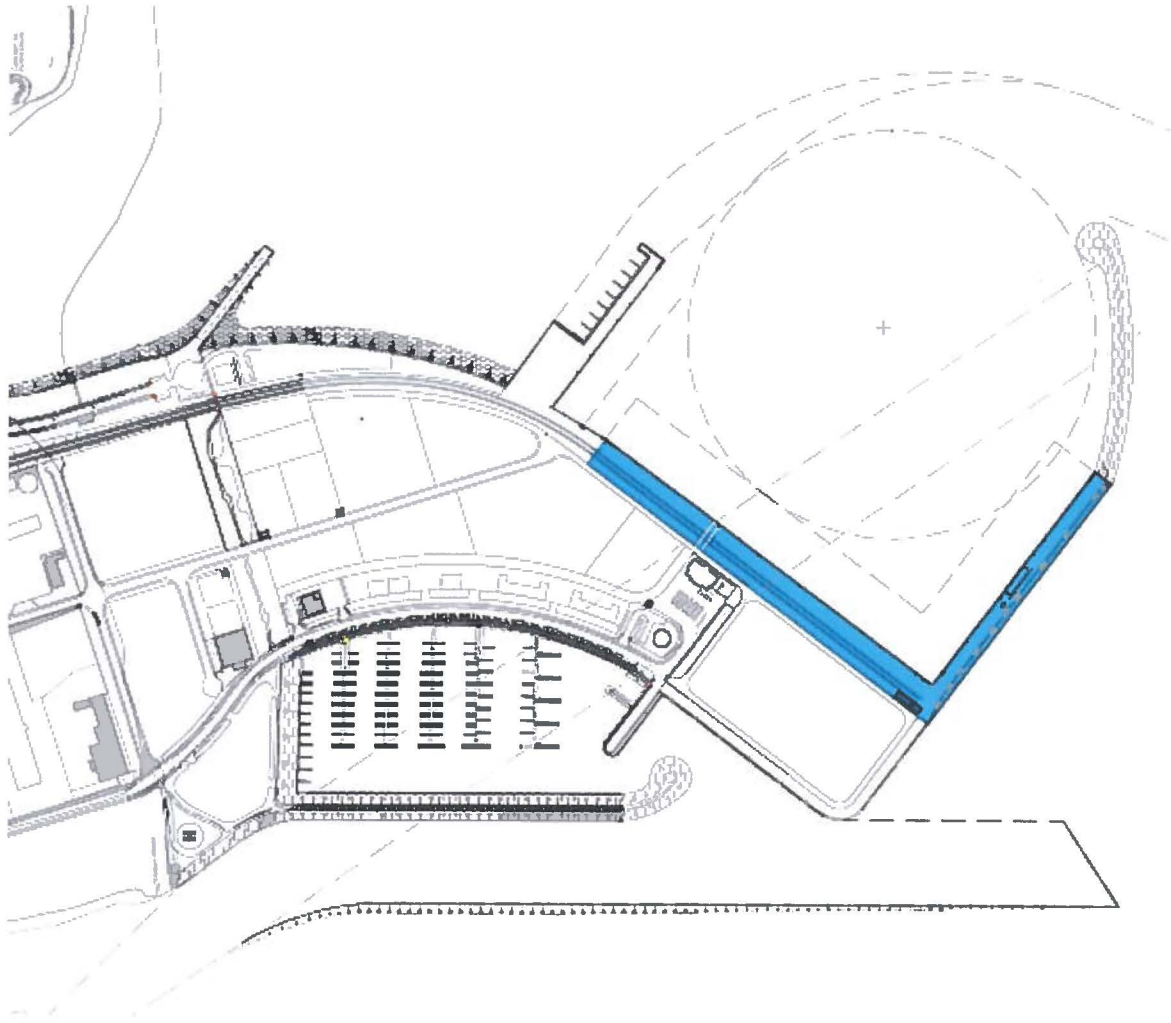

Deepwater Quays

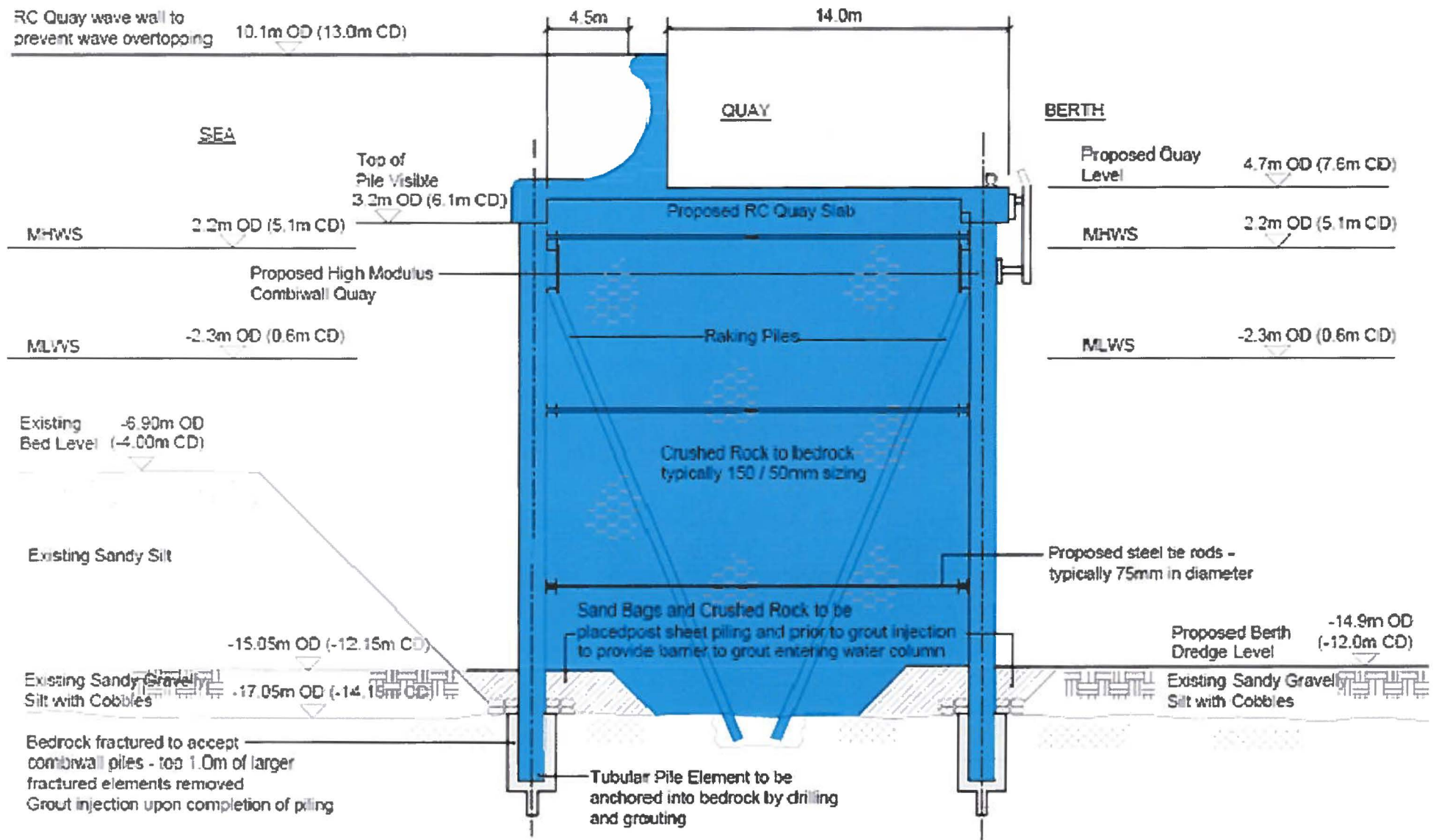

Quay Wall Construction

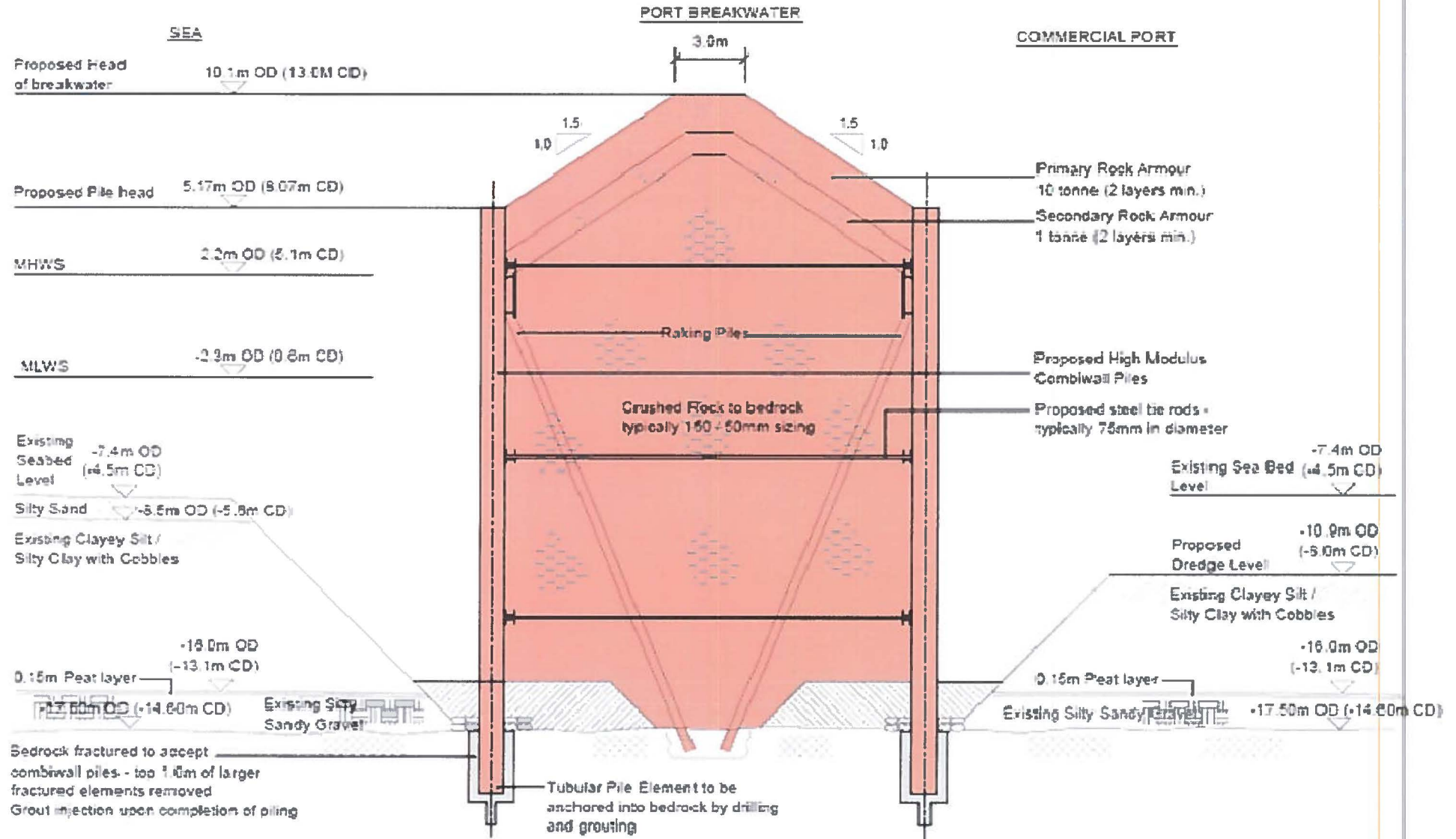

Commercial Port Breakwater Design

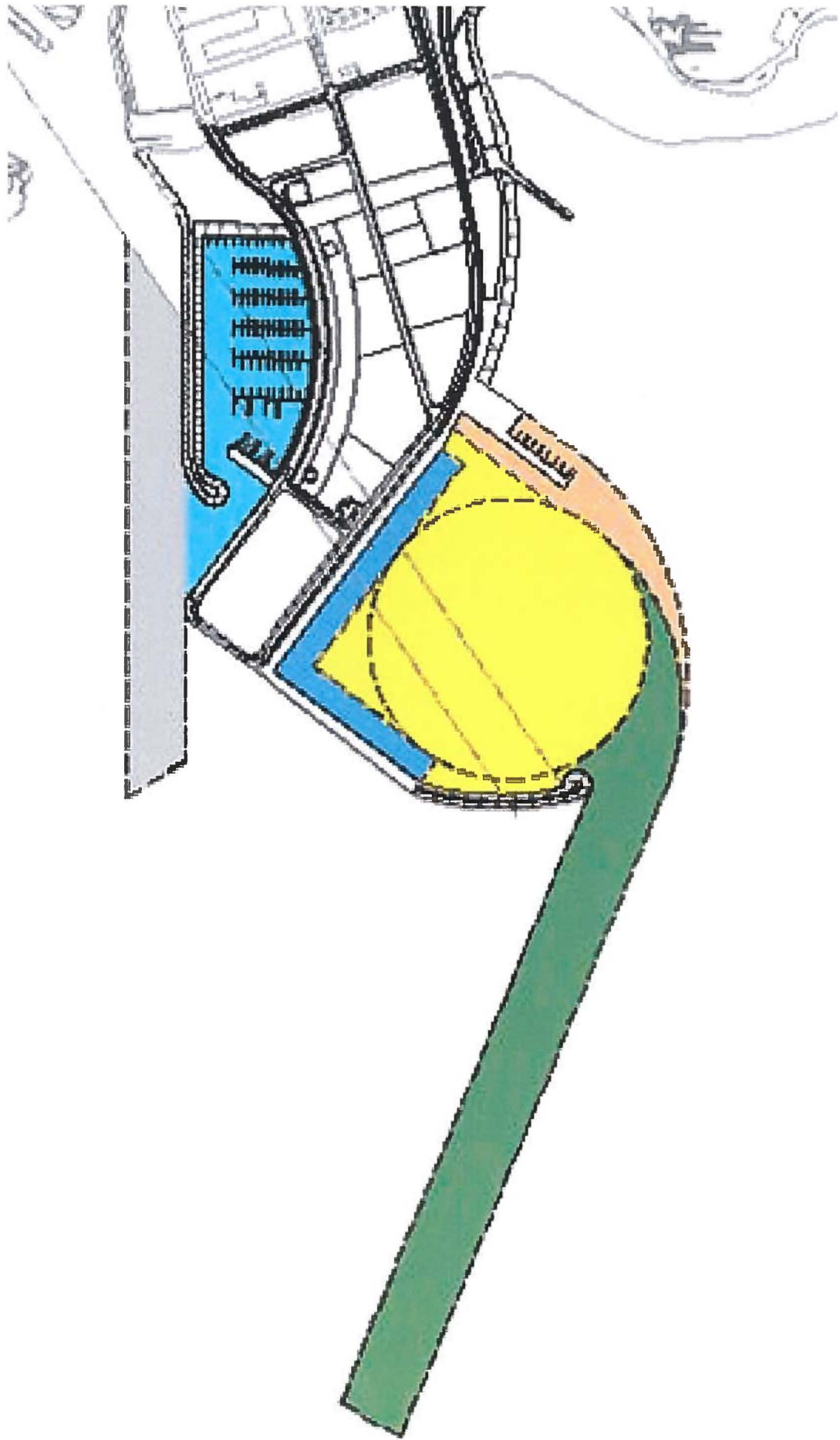

Dredging Locations



- 1 = Draghead
- 2= Suction Pipe
- 3= Hopper
- 4= Bottom Doors
- 5= Pipeline pump out point

©  Royal
Boskalis Westminster nv

Typical Trailer Suction Hopper Dredger



TSHD Pumping Onshore via Floating Pipeline



Backhoe Dredger Loading to a Barge